

INVEST IN TIME



PASSENGER CARS



LIGHT COMMERCIAL



FUEL HANDLING

SPECIAL TOOLS FOR AUTO REPAIRS

WALLMEK
í Kungälv AB

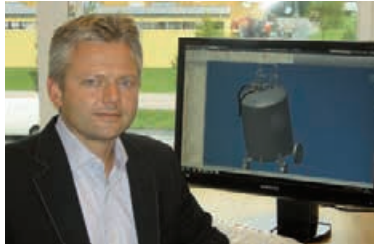

Company profile:

Wallmek i Kungälv AB was started in 1978, producing and designing special tools for car repairs. Wallmek stands for idea and design of tools, up to delivery of a complete product to the customer. Our products are in the segments of chassis tools and liquid handling equipment.

The Wallmek research and development department works in close cooperation with automotive workshops to ensure the best possible productivity, ergonomics and health. We are very good at designing hydraulic tools that enable repairs directly on the car, handling of fuel when tank repairs are necessary and to make drainage systems for car dismantlers. Today Wallmek is developing tools directly for car manufacturers, after market and garages. For the car dismantling industry, we develop tools for draining all liquids from the cars to make them environmentally decontaminated.

As the company continues to expand, we are now also involved in customer segments like trucks, trailers and constructions machinery. In short terms – we develop Wallmek in a direction where our products make the best use for our customer.

Our mission:

To develop, produce and market our cost effective tools to our customers.

Important for us:

- Quality! – To exceed the customers expectations.
- Design! – Ergonomic, well thought out and functional products.
- Customer care! – Being present and always available for support.

Welcome to Wallmek i Kungälv AB

Niklas Wallman
Managing Director

The information “patent pending”, regarding patent applications for certain products in this brochure, only concerns the patent application Nos. (and markets covered by that patent application) explicitly stated in the immediate connection with patent pending indication.



Labourtime



QR code video



Position on vehicle

04-00024 Hydraulic ball-joint puller

New, unique design and function for dismantling the conic bolts on passenger cars and light commercial vehicles with ease. The tool is developed for the new front suspensions with longer conic bolts often fitted in aluminum cones.

These fittings sit harder and are also more fragile than the older steel versions. The press tool has two different heights to choose from, 61 or 73 mm. Stroke 25 mm.

The anvil tool has two different opening sizes, 26 or 32 mm.

Both of the tools can switch position for superior access in tight areas of the wheel suspension. The hydraulic cylinder presses 4,5 Tons and give a safe and problem free dismantling.

To increase the safety even further the tool is delivered with a safety strap. This will prevent the tool from falling down during operation.

The tool is used with a 700 bar hydraulic pump 1030 or 1036.

Pat Pending No. EP17179578.4 and US Patent Application 16/021.868



Parts in the set:

1. 04-00024-021 – Press tool
2. 04-00024-022 – Anvil tool
3. 04-00024-020 – Distance ring
4. 04-00024-011 – Safety strap
5. RES4305 – Cejn nippel 1/8"

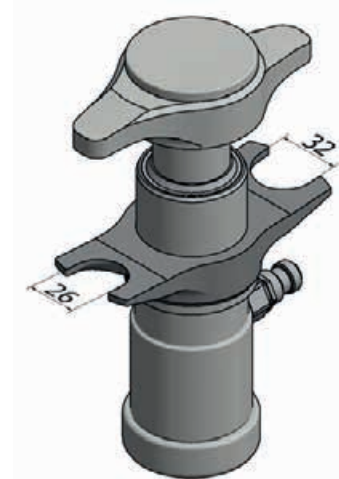
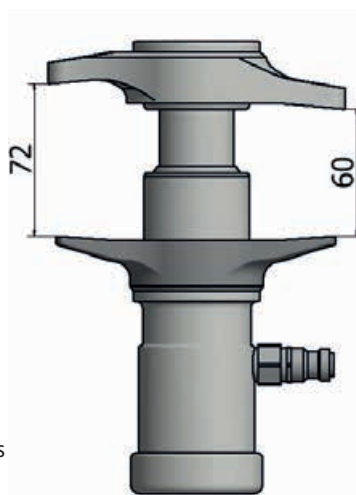

Dismounting and mounting of wheel studs.

Avoid hammering when replacing wheel studs, the bearing will get damages inside. The studs can easily be replaced with this new ball joint tool.

Hydraulic cylinders

01-00030 Hydraulic cylinder 18 ton

18 tons pressing and pulling "light weight" hydraulic cylinder in a compact size with automatic return of the piston, **only 2,8 kg**. Designed for everyday use in auto repair shops. Can be used with all of our passenger car tools and carriage beams M10-M22 with the proper adaptor.

The cylinder's hydraulic pressure can be combined with punching force when using the punching socket 1086-6. For example when pressing a rusted axle shaft. Stroke: 50 mm.

Automatic return.

Patent Pending European Application No. EP15189415.1
US Patent 10.047.772B2



Parts in the set:

1. 01-00030-001 - Hydraulic cylinder 18 ton
2. Res 4306 - Hydraulic quick coupling
3. Res 4026 - Carriage beam M18/M22, 250mm
4. Res 1090-01-09 - Press plate M24x3
5. Res 4024 - Flange nut M18
6. 1086-6 - Punching socket M22x2,5
7. Res 1090-01-10 - Adjustable press rod 100mm, M24
8. Res 1090-01-12 - Adjustable press rod 132mm, M24
9. 01-00030-005 - Press rod
10. 09-1090-01-11 - Lid for back end

1090-02-WAL Hydraulic cylinder 22 ton

22 tons pressing and pulling hydraulic cylinder in a compact size with automatic return of piston. Designed for everyday use in auto repair shops.

Can be used with all of our passenger car tools and carriage beams M10-M22 with the proper adaptor. The cylinder's hydraulic pressure can be combined with punching force when using the punching socket 1086-6. For example when pressing a rusted axle shaft. Weight: 4,7 kg. Stroke: 70 mm. **Automatic return.**



Parts in the set:

1. 1-1090-02 - Hydraulic cylinder 22 ton
2. 1086-6 - Punching socket M22x2,5
3. RES 1090-01-09 - Press plate M24x3
4. RES 1090-01-10 - Adjustable press rod 100mm, M24
5. 09-1090-01-11 - Lid for cylinder gable
6. RES 1090-02-04 - Press axle 151mm, M24x3
7. RES 1090-05-02 - Adjustable press rod 109mm, M24
8. RES4024 - Flange nut M18
9. RES4026 - Carriage beam M18/M22, 250mm
10. RES4306 - Hydraulic quick coupling, male

1090-03 Hydraulic cylinder 14 ton

14 tons pressing hydraulic cylinder in a very compact size. Designed for everyday use in auto repair shops. Specially designed to use with press blocks 1090-55-B, 1090-60 and 1090-69. Weight: 2,5 kg. Stroke: 55 mm.

Automatic return.

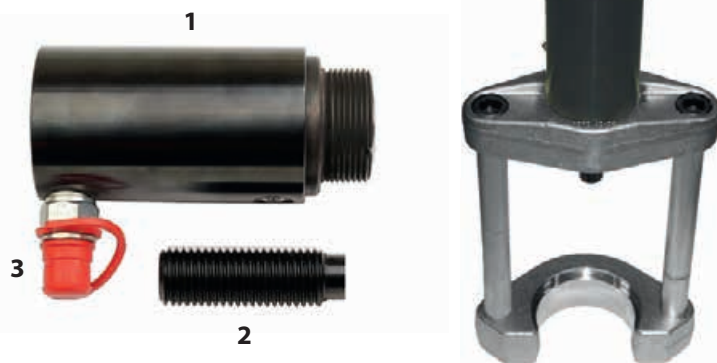

Parts in the set:

1. 1-1090-03 - Hydraulic cylinder 14 ton
2. RES 1090-01-10 - Adjustable press rod 100mm, M24
3. RES4306 - Hydraulic quick coupling, male

03-00015 Hydraulic cylinder 8,5 ton

A very compact cylinder for pressing and pulling. The cylinder comes with an adjustable press rod and a punching socket. This cylinder is very flexible and easy to use also in narrow areas. Specially designed to be used with 03-00014-001 and 03-00005-001. Weight: 1,8 kg. Stroke: 25 mm. **Automatic return.**



Parts in the set:

1. 03-00015-001 - Hydraulic cylinder 8,5 ton
2. 03-00015-006 - Punching socket with o-ring
3. 03-00015-012 - Adjustable press rod 100mm, M22
4. RES4305 - Hydraulic quick coupling, male, 1/8"

03-00028 Hydraulic cylinder 32 ton

32 tons pressing and pulling hydraulic cylinder.

Designed for everyday use in auto repair shops. Primarily for use with our wheel bearing tools for light commercial vehicles and trucks.

Can be used with carriage beams M10-M22 with the proper adaptor. The cylinder's hydraulic pressure can be combined with punching force when using punching socket 1086-6 or punching nut 1091-17-M22. Weight: 8,2 kg. Stroke: 112 mm.

Automatic return.

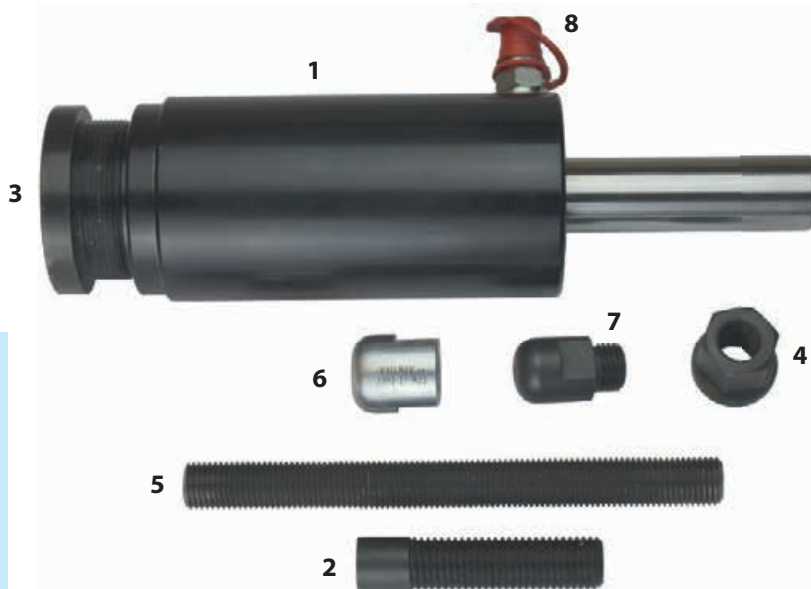

Parts in the set:

1. 03-00028-001 - Hydraulic cylinder 32 ton
2. RES 1090-05-02 - Adjustable press rod 109mm, M24
3. RES 1090-05-04 - Thread protection ring (2,5")
4. RES4025 - Flange nut M22
5. RES4027 - Carriage beam M22, 250mm
6. 1091-17 - Punching nut M22
7. 1086-6 - Punching socket M22
8. RES4306 - Hydraulic quick coupling, male

01-00031 Punching nut M18

When punching force is needed for pulling with our hydraulic cylinders. Useful for hubs and wheel bearing removal. Also used with the manual carriage beam 01-00020. Depending on hammer size, the extra force is similar as 2,5 – 3,5 times more power than the cylinder power itself.



1086-6 Punching socket M22

To be used on the piston side of the cylinder when pressing out axle shafts e,t,c. The punching socket allows striking by a hammer in the cylinders press direction. Depending on hammer size, the extra force is similar as 2,5 – 3,5 times more power than the cylinder power itself.



03-00015-020 Press foot M22

Fit's the press side of the 8,5 Ton hydraulic cylinder 03-00015-020. The press plate can be used instead of the adjustable press axle delivered with the cylinder.



04-00021 Cylinder holder Ø65-100 mm

Developed for use with the following cylinders; 1090-02-WAL, 1090-03 and 03-00028/ 01-00030. The holder is designed for use on the cylinders with hand held use and for use on a floor stand or gear box lift. Adjusting and locking of the cylinder is very easy and flexible for simple use. Also other cylinder brands and types from Ø65 – 100 mm can be mounted in the holder.

Fit's gearbox lift and floor stand with axle measure from 25/30 mm.



Parts in the set:

- 04-00021-001 - Holder without clamps
- 04-00021-013 - Clamp Ø70 mm
- 04-00021-014 - Clamp Ø85 mm
- 04-00021-015 - Clamp Ø100 mm

Use with cylinder:

- 1090-01 (16 T)
- 1090-02 (22 T)
- 1090-03 (14 T)
- 03-00028 (32 T)
- 01-00030 (18 T)



Hand held



Gearbox lift and floor stand

01-00020 Carriage beam set manual wheel bearing replacement

Carriage beam set for manual use of wheel bearing tools. The set is used by hand or with an impact air gun. It's designed for the following tool sets: 01-00035, 1090-20, 1090-25, 1090-26, 1090-27, 01-00018, 01-00026, 01-00027, 01-00037 and 01-00038. For more frequent work we recommend using our hydraulic cylinders instead.



Parts in the set:

1. 01-00020-001 - Carriage beam M18, 330mm with nut
2. 01-00020-002 - Plate 19x45x5
3. 01-00020-003 - Press plate
4. RES4024 - Flange nut M18

01-00020-100 Press plate, adaptor for 01-00035

Option for the manual carriage beam set 01-00020. The press plate makes it possible to use the front wheel bearing set 01-00035 also for manual use, without hydraulic.

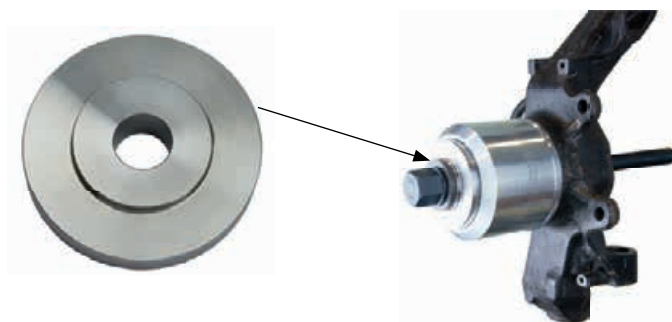

01-00039 Manual press rod set

The set comes with four different press axles for adaptation with the different tool sets. All parts are dimensioned and designed for use with 1/2" impact gun, ratchet or wrench with 27 mm. The real power is up to 15 ton, it's to be compared with the 8 Ton that can be measured with a normal grease spindle on the market. The threads, harder material and the special bearing make it possible to use a 1/2" impact gun with up to 1000 NM without damaging the tool. For frequent jobs on ball-joints, bushings and axle shafts our hydraulic cylinders from 8,5 – 22 ton is recommended.

01-00039 can be used with the tools bellow.



01-00039 with 01-00022 on Volvo V70



Parts in the set:

1. 01-00039-001- Press rod M30
2. 01-00039-002- Adaptor 1 1/2" – M30
3. 4 pcs 01-00039-003- Washer Ø 18,8 x 3 mm
4. 01-00039-010 - Press axle 50 x Ø 19 mm
5. 01-00039-011- Press axle 85 x Ø 19 mm
6. 01-00039-020 - Press axle 56 x Ø 24 mm
7. 01-00039-021- Press axle 100 x Ø 24 mm
8. 09-874-3010 - Litium grease



Adaptors for other tool systems

1. **1068-04** Adaptor 1 ½" to 2 ¼" – 14UNS (Klann thread)
2. **1068-05** Adaptor 1 ½" to G2 ½" – 11 (16 and 22 ton cylinder - 32 tons cylinder thread)
3. **1068-06** Adaptor 2 ¼" – 14UNS (Klann thread) to 1 ½"
4. **1068-07** Adaptor 1 ½" to M55x1,5 (Volvo thread)
5. **1068-08** Adaptor 1 ½" to M68x2 (Paschke thread)
6. **1068-09** Adaptor M68x2 (Paschke thread) to 1 ½"
7. **1068-10** Adaptor 2 ¾" – 16UNS G2 ½" (Klann thread) to 2 ½"
8. **1068-11** Adaptor 2 ¾" – 16UNS G1 ½" (Klann thread) to 1 ½"

1090-32 Carriage beam, flange nut & adaptor set

Set of carriage beams, flange nuts and adaptors.

Parts in the set:

1090-32-10



RES4014

Carriage beam M10, 150 mm in 12.9 quality.



RES4012

Adaptor M22 → M10



RES4023

Flange nut M10

1090-32-12



RES4015

Carriage beam M12, 250 mm in 12.9 quality.



RES4011

Adaptor M22 → M12



RES4022

Flange nut M12

1090-32-14



RES4016

Carriage beam M14, 250 mm in 12.9 quality.



RES4010

Adaptor M22 → M14



RES4021

Flange nut M14

1090-32-18



RES4026

Carriage beam M18/M22, 250mm in 12.9 quality.



RES4024

Flange nut M18

1090-32-22



RES4027

Carriage beam M22, 250mm in 12.9 quality.



RES4025

Flange nut M22

04-00008-001 Carriage beam M10, 1000 mm

Produced in 12:9 quality, can also be ordered in ½
(delivered then in 500 mm length)

04-00008-002 Carriage beam M12, 1000 mm

Produced in 12:9 quality, can also be ordered in ½
(delivered then in 500 mm length)

04-00008-003 Carriage beam M14, 1000 mm

Produced in 12:9 quality, can also be ordered in ½
(delivered then in 500 mm length)

04-00008-004 Carriage beam M22, 1000 mm

Produced in 12:9 quality, can also be ordered in ½ (RES4034)
(delivered then in 500 mm length)

04-00008-005 Carriage beam M18, 1000 mm

Produced in 12:9 quality, can also be ordered in ½
(delivered then in 500 mm length)



RES4036

Carriage beam M27, 330 mm in 10.9 quality.



RES4035

Flange nut M27



RES4037

Carriage beam M27, 500 mm in 10.9 quality.



RES4008

Adaptor M27 → M24



RES4039

Adaptor M27 → M22



RES4009

Adaptor M22 → M18

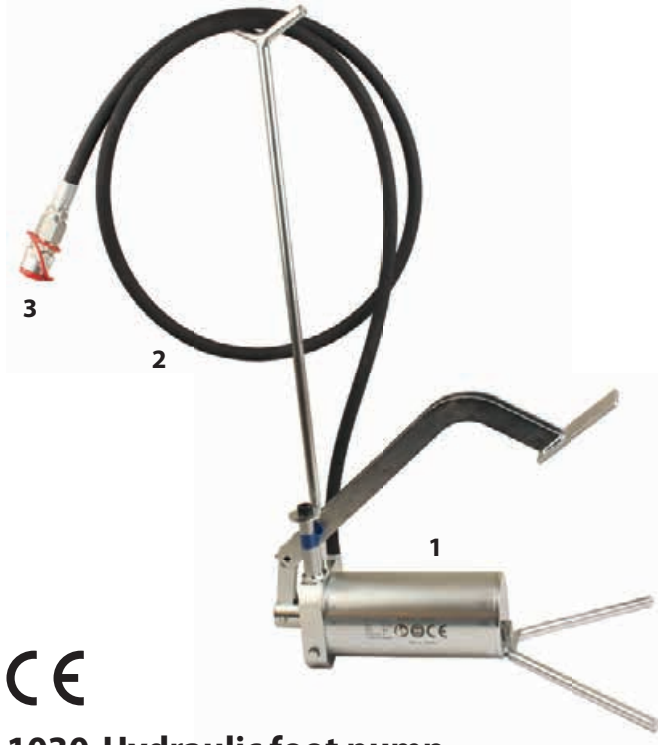

1030 Hydraulic foot pump

Hydraulic foot pump 700 bar for use with all of our hydraulic cylinders. 2,2 m hose and drip-free quick coupling. Oil tank volume 0,75 litres.

Parts in the set:

1. 1-1030 - Hydraulic foot pump
2. RES 1030-02 - Hydraulic hose for 1030 & 1035
3. RES4304 - Hydraulic quick coupling, female



1036 Pneumatic, variable hydraulic pump



Pneumatic driven hydraulic pump with variable speed for better control. Max pressure 700 bar for use with all of our hydraulic cylinders. The pump is delivered with a pressure gauge next to the pedal and 2,2 m hose and drip-free quick coupling. Oil tank volume 1,3 litres.

Parts in the set:

1. 1-1036 - Pneumatic, variable hydraulic pump
2. RES 1030-02 - Hydraulic hose for 1030, 1035 & 1036
3. RES4304 - Hydraulic quick coupling, female



04-00020 Hydraulic oil 1 L

High quality hydraulic oil, optimal for Wallmek's hydraulic tools and pumps. Regular hydraulic oil change and correct volume increases the operation time of the components.



04-00016 Pressure gauge set for hydraulic pumps 1030 and 1035

A complete kit with coupling and nipple for connection directly to any Wallmek hydraulic pumps. The hydraulic cylinders manual includes a chart that shows the maximum oil pressure in bars for each different carriage beam.



04-00015 Safety cover with catch strap

Additional item for hydraulic operation directly on the car. Prevents damage if parts brakes or falls down.

INVEST IN TIME



After a few years on the road it's a time-consuming effort to dismount most parts that's been exposed to water, salt and wear. With the right design and function of the tool system there are many hours to be saved every day when working under the vehicle.

The Wallmek tool system gives the shop the possibility to work more efficient and easier. The basic parts in the tool system are used for many different models and type of jobs, this makes the investment even more obvious, economical and efficient.

The right tools in not a cost, it's the best investment in the technician's potential to get the job done quicker and safer. The expensive tool is the one that doesn't get the job done at all or break due to bad quality when you need it the most.

Today's shops want skilled and experienced technicians that doesn't get injured due to his job. Ergonomics and working environment are the basic things that makes it possible to keep the best technicians in the shop, loving what they do. The shop will then increase the productivity and the skill level gets higher every day.

Wheel bearings of different types requires the right tool for correct, efficient and quick replacement.

Generation 1

Pressed in wheel bearings with separate hubs. This type has been used in cars since the 70s and are still very common in modern cars. The hub dismantling is made with **01-00037**, **1090-22**, **1090-26** or **01-00018** when the space between the knuckle and hub is enough. The bearing itself are replaced with **01-00035**.

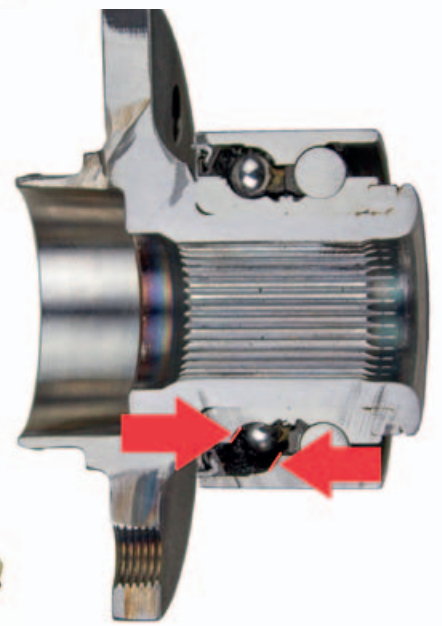

Generation 2

Pressed in wheel bearings with integrated hubs, also called HBU 2.1 or compact wheel bearings. This wheel bearing type is mounted in vehicles since 2002 and are today mounted in the majority of brands and sizes of cars and light commercial vehicles. From VW Lupo up to Mercedes Sprinter/VW Crafter. Mounting is made by pressing only on the bearing! By pressure on the hub the wheel bearing race will be damaged by the balls inside. The ABS magnet ring can also get damaged. A correct mounting of any size is made with **01-00033**. For correct dismantling **01-00018** is used.



Generation 3

Bolted on bearings are often used in aluminum knuckles but also frequently used in steel knuckles. The small tolerance in combination with long guiding in to the knuckle causes huge problems after some years when demounting the bearing. To avoid damaging or dismantling the wheel knuckle **01-00026**, **01-00027** or the brand new **01-00047** is used.

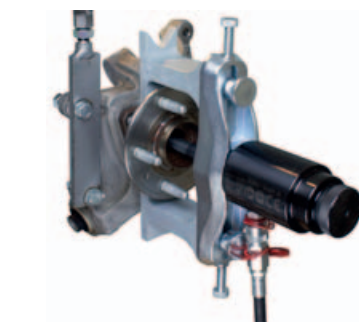

Bearing, axle shaft & hub sets

See each set for recommended cylinder.

UPGRADED!

Generation 1

01-00037 Hub dismantling tool, universal

New efficient method for hub dismantling, recommended for use with front wheel bearing set 01-00035. This new tool is designed to fit the majority of passenger cars with separate hub and wheel bearing. The method allows access also when the knuckle has uneven surfaces or fragile brake shields behind the hub. These type of vehicles otherwise require many different special tools or time consuming dismantling. The tool is used according the following two steps.

Step 1 clamping the two press feet together with a hydraulic cylinder behind the hub, pressing the hub from the bearing.

Step 2 pulls the hub out from the bearing.

The two press feet's (01-00037-020) can be ordered separate for use in any of the following tools; 01-00018, 01-00026, 01-00027, 01-00047 and 01-00033. (Used with cylinder 1090-02-WAL/01-00030*)

*If the tool is used with cylinder 01-00030 press pipe 01-00001-203 are also needed, not included.

(Used with hub plate 01-00035-001, 002, 003.)

Patent Pending - European Patent Application No. EP15194783.5
Protected Design within EU - RCD No. 003477090-0001/0002
Patent Pending - European Patent Application No. EP16200076.4
US Design Patent Pending - US Patent Application No. 29/604 325



Press foot set 01-00037-020



Parts in the set:

1. 2 pcs 01-00037-001 – Press foot
2. 01-00041-002 – Fixing plate
3. 2 pcs 01-00018-003 – Knob screw set
4. 2 pcs 01-00018-004 – Screw



1090-22 Press clamp, axle shaft & hub dismantling

Durable design with three press legs for efficient hub dismantling up to 22 ton. Suitable for vehicles/knuckles with flat surface behind the hub. Also axle shaft pressing is possible when using the pressing side on the following cylinders; 1090-02-WAL (22 T) and 01-00030 (18 T).



1090-26 Large bearing & hub cup

For dismantling of wheel bearings & hubs. This cup can be used on models that the standard press clamp (1090-22) don't fit on. For example Volvo S40/V50, Ford C-Max & Mazda 3. Also some models from Citroën, Peugeot, Renault & VAG. Rec. cylinder 1090-02-WAL/01-00030.

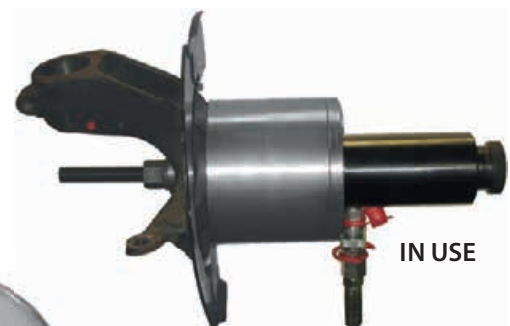

Parts in the set:

1. 1090-26-01 - Large press plate, two sided.
2. 1090-26-02 - Large press pipe, two sided.



Generation 1

01-00035 Universal front and rear wheel bearing set for passenger cars

This new set are developed for todays and coming generation of wheel bearings, front and rear. The job is made directly on the vehicle with a big time save as a result, ABS sensors and most of the suspension is left untouched. The set are also a base for several specific jobs and models, easy to build further on. All parts are developed and adapted for today's wheel bearing and hub sizes.

The mounting plates has a built in guiding function and, they are two sided with to fit perfect on 62 – 83 mm Ø wheel bearings. The bearing cup can fit wheel bearings up to 92 mm Ø. Hub dismounting is made with optional tools for the best function 01-00037, 01-00018, 1090-22, 1090-26, 1064.

Rec. Cylinder 1090-02-WAL (22T) and 01-00030 (18T).



Parts in the set:

- | | |
|--|---|
| 1. 01-00035-001 Hub plate, coned, Ø33,8 mm* | 9. 01-00035-014 Bearing plate Ø72,5-74,5 mm* |
| 2. 01-00035-002 Hub plate, coned, Ø38,8 mm* | 10. 01-00035-015 Bearing plate Ø76,5-78,5 mm* |
| 3. 01-00035-003 Hub plate, coned, Ø43,8 mm* | 11. 01-00035-016 Bearing plate Ø80,8-82,8 mm* |
| 4. 01-00035-004 Hub plate, coned, Ø59,8 mm* | 12. 01-00035-020 Bearing cup Ø93 mm |
| 5. 01-00035-010 Bearing plate Ø61,8-62,8 mm* | 13. 01-00035-021 Adaptor ring Ø76,5 mm |
| 6. 01-00035-011 Bearing plate Ø63,8-64,8 mm* | 14. 01-00035-022 Adaptor ring Ø82,5 mm |
| 7. 01-00035-012 Bearing plate Ø53,8-66,8 mm* | 15. 01-00035-030 Press pipe L=78 mm |
| 8. 01-00035-013 Bearing plate Ø68,8-70,8 mm* | 16. 1090-20-M Holder* |

*Inner Ø 20,25 mm



Generation 1

01-00036 Adjustable bearing fixture for wheel bearings dismounted inwards

Designed to fit on the majority of models where the wheel bearing is dismounting towards the vehicle. This type is now common on newer models from several brands as; Citroen, Peugeot, Fiat, Renault, Opel, Mercedes, Kia and Hyundai. The set contains two press feet's mounted on a holder (1090-20-M that also are included in the wheel bearing set).

The press feet's 01-00036-020 can be ordered separately and be used with wheel bearing set 01-00035

Rec. Cylinder 1090-02-WAL/01-00030.

Parts in the set:

1. 2 pcs 01-00036-001 - Adjustable bearing fixture
2. 1090-20-M - Holder



01-00036-02

01-00038 Wheel bearing and hub set front/rear Audi Q7/VW Touareg/Porsche Cayenne

The wheel bearing is replaced directly on the car without time consuming dismounting. The entire job is about 30 minutes with this set. The parts are designed to protect the ABS-sensor and other sensitive parts. **Hub dismounting is made very easy with 01-00037. Bearing dismounting with 01-00018, is not included in the set.**

Rec. Cylinder 1090-02-WAL/01-00030.

Parts in the set:

1. 01-00035-003 - Hub plate, coned, Ø43,8 mm
2. 01-00035-012 - Bearing plate Ø65,8-66,8 mm*
3. 01-00035-030 - Press pipe L=78 mm
4. 1090-20-T21 - Bearing plate Ø92*
5. 1090-20-T22 - Bearing plate Ø95*

*Inner Ø 23 mm

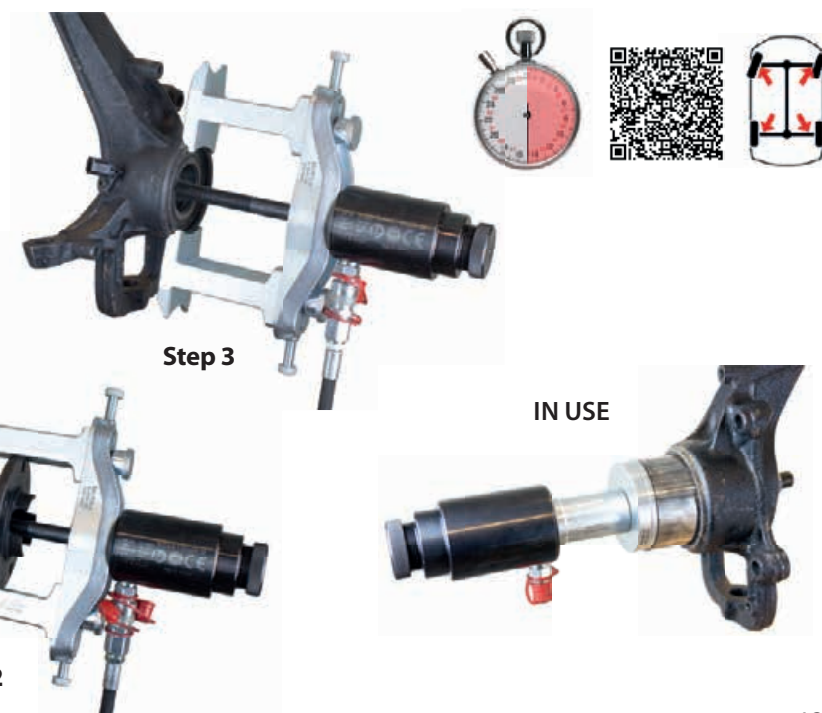

Step 1

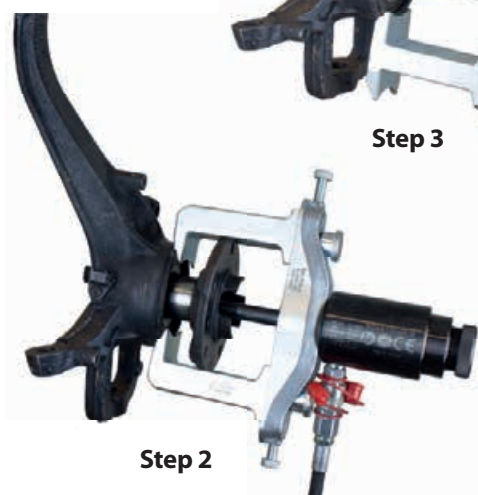

Step 2

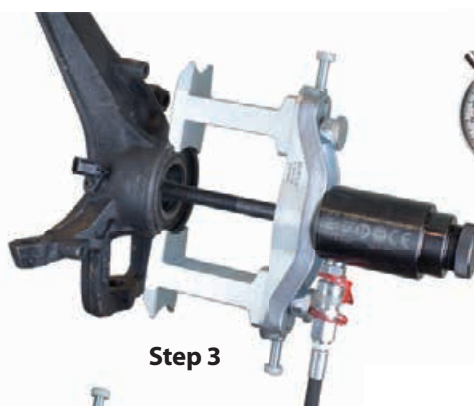

Step 3

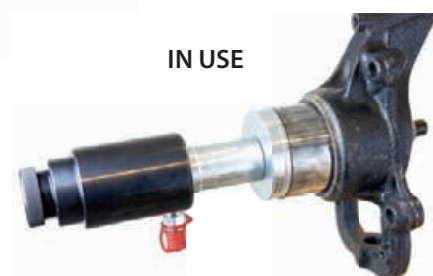

IN USE

Generation 2

01-00033 Compact wheel bearing mounting tool

New improved method, adaptable with our unique dismounting tool 01-00018-020!

Universal tool for **mounting** the new type of compact wheel bearings, with or without locking ring. It's adjustable to fit future bearing sizes and all current VW Lupo, Polo Transporter 5 and 6, Audi A2, Seat Cordoba and Skoda Fabia. Volvo V50/S40, V40, C30, V70/ S80 and XC60. Ford Focus, C max, Mondeo, S-Max and Kuga. Mazda 3 and 5. Landrover Freelander 2. Mercedes Vito and Sprinter. Mitsubishi Colt, Smart Forfour, Peugeot, Citroen and Toyota with this type of bearing.

This tool can also be used in the garage press.
Rec. cylinder 1090-02-WAL/01-00030.

European Patent No. EP3117961
Protected Design within EU - RCD No. 002807438-0001/0003
Patent pending - US Patent Application No. 15/204,525
Protected Design within EU - RCD No. 003477090-0001/0002
Patent Pending - European Patent Application No. EP16200076.4
US Design Patent Pending - US Patent Application No. 29/604 325

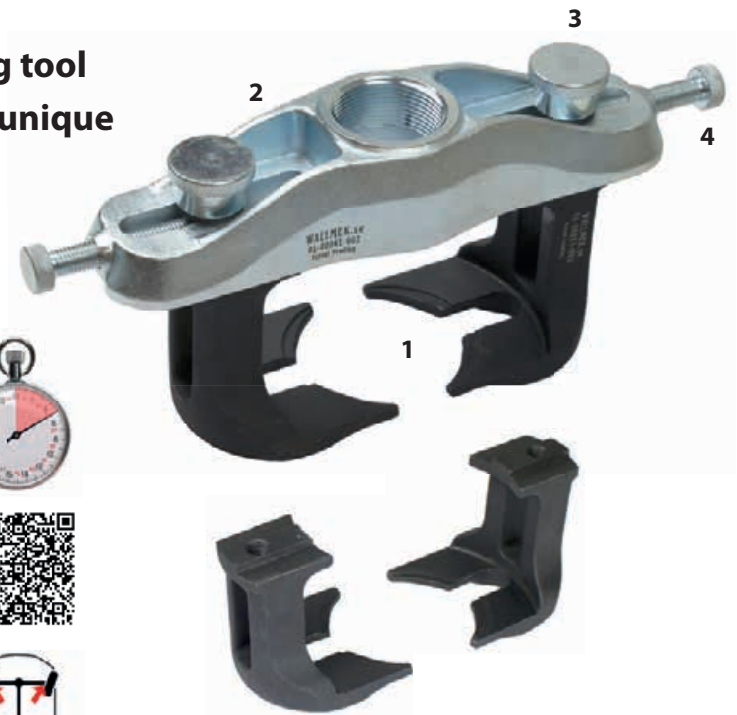

Press foot set 01-00033-020

Parts in the set:

1. 2 pcs 01-00033-001 – Press foot
2. 01-00041-002 - Fixing plate
3. 2 pcs 01-00018-003 - Knob screw set
4. 2 pcs 01-00018-004 - Screw



1090-25-11 Holding plate

For mounting compact wheel bearings on VW Lupo, Polo 9N and equivalent models on Audi, Seat and Skoda with 01-00033 or 1090-25. Mitsubishi Colt och Smart Forfour. Inner Ø 21 mm.



1090-25-13 Mounting ring

For mounting compact wheel bearings on Ford Mondeo, S-Max and Volvo V70 etc. 2007- with 01-00033 or 1090-25.



1090-25-12 Holding plate

For mounting compact wheel bearings on VW T5 and diesel Touareg models with 01-00033 or 1090-25. Inner Ø 20,25 mm.



1090-25-14 Holding plate

For mounting compact wheel bearings on Ford Mondeo, Volvo V70 etc. 2007-, Ford Focus, Mazda 3 and 5, Volvo S40/ V50 2004- also Ford Focus C-max. S-Max, Kuga, Freelander 2 with 01-00033 or 1090-25. Inner Ø 20,25 mm.



1090-25-14 Mounting ring

The mounting ring is needed for a correct mounting of the rear wheel bearing on Peugeot Expert (Traveller), Citroen Jumpy (Spacetourer) och Toyota Proace (Proace Verso) 2016 -. To be used with mounting tool 01-00033 or 1090-25.

NEW!

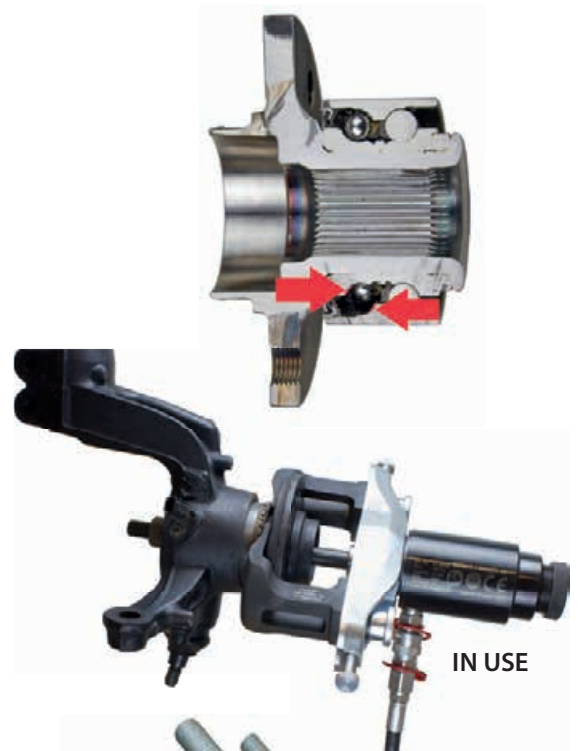

Generation 2

01-00018 Compact wheel bearing dismounting tool

Universal tool for **dismounting** the new type of compact wheel bearings, with or without locking ring. Max pressure 22 ton. It's adjustable to fit future bearing sizes and all current VW Lupo, Polo, Transporter 5 and 6, Touareg, Audi A2, Seat Cordoba and Skoda Fabia. Volvo V50/S40, V70/ S80 and XC60. Ford Focus, C max, Mondeo, S-Max and Kuga. Mazda 3 and 5. Landrover Freelander 2. Mercedes Vito and Sprinter. Mitsubishi Colt, Smart Forfour, Peugeot, Citroen and Toyota with this type of bearing. This tool can also be used as a hub puller on most other cars, also BMW.
Rec. cylinder 1090-02-WAL/01-00030.

Protected Design within EU - RCD No. 003477090-0001/0002
Patent Pending - European Patent Application No. EP16200076.4
US Design Patent Pending - US Patent Application No. 29/604 325

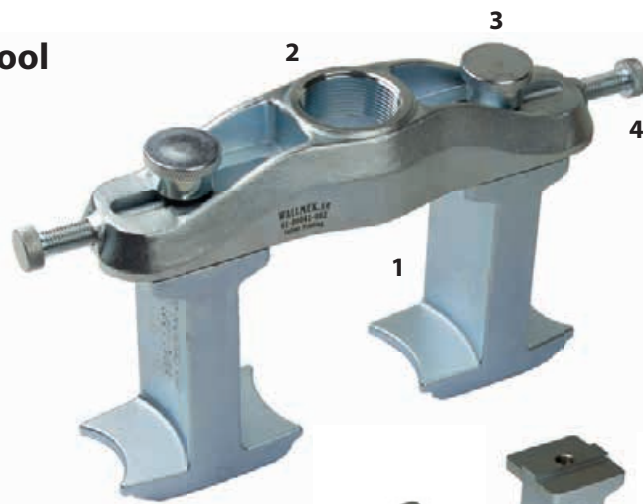

Press foot set 01-00018-020

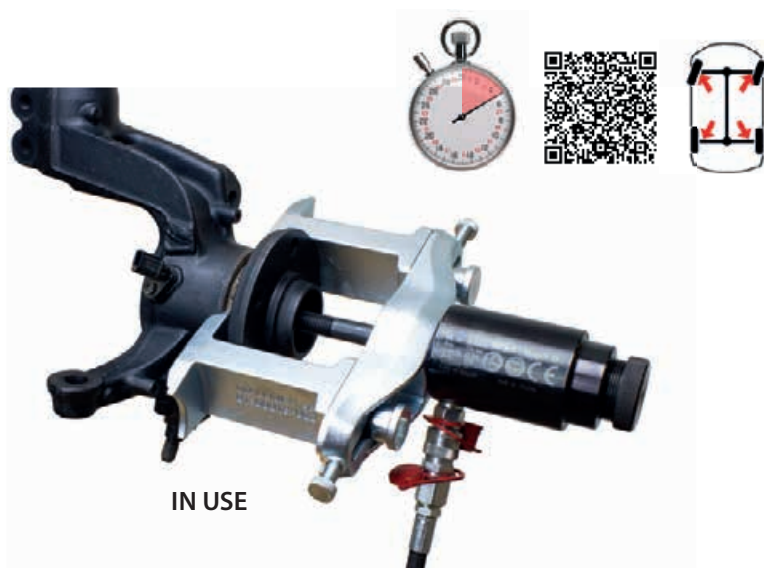

IN USE



1090-25-10 Coned dismounting plate (universal)

Plate for dismounting compact wheel bearings. Fits all sizes. Inner Ø 21 mm.



Parts in the set

1. 2 x 01-00018-002 - Press foot
2. 01-00041-002 - Fixing plate
3. 2 x 01-00018-003 - Knob screw set
4. 2 x 01-00018-004 - Screw

02-00012 Rear wheel bearing set Peugeot Expert (Traveller), Citroen Jumpy (Spacetourer) och Toyota Proace (Proace Verso) 2016 -

NEW!



For more info see page 25.

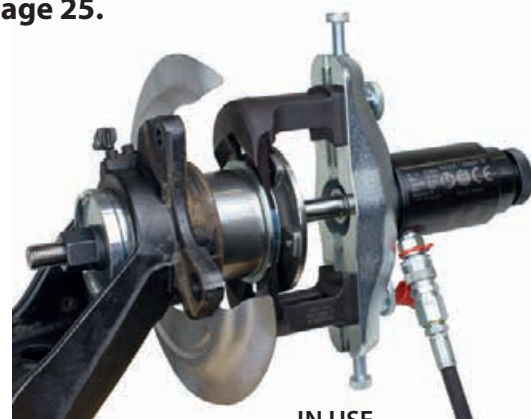

IN USE

Generation 3

01-00026 Dismounting tool Bolted (4 bolts) wheel bearing/hub

The tool is adjustable and designed to dismantle bolted wheel bearings with guides that usually rust in the wheel spindles. Extraction can be done with a full 22 ton directly on the vehicle, while the hub can also be dismantled in instances where this will be reused in the new bearing. Both press feet have two different sides, which are selected according to the vehicle/bearing design, adjustment is very easy. Designed and tested on the majority of 4 bolted wheel bearings. Front and rear on: VW, Audi, Seat, Skoda, Volvo, Ford, Mazda, Toyota, Mitsubishi etc. See page 18–19.

Press foot 01-00026-001 used in pairs (01-00026-020) and can be ordered separately for use in tool 01-00018 (dismounting tool compact wheel bearing). (Used with hub plate 01-00035-001, 002, 003, 004.)

Rec. cylinder 1090-02-WAL/01-00030.

Protected Design within EU - RCD No. 003477090-0001/0002
Patent Pending - European Patent Application No. EP16200076.4
US Design Patent Pending - US Patent Application No. 29/604 325

Parts in the set:

1. 2 x 01-00026-001 - Press foot
2. 01-00041-002 - Fixing plate
3. 2 x 01-00018-003 - Knob screw set
4. 2 x 01-00018-004 - Screw



Press foot set
01-00026-020

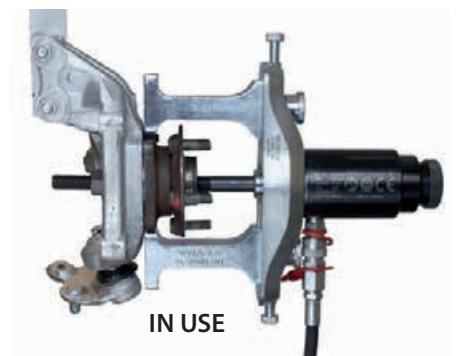

01-00027 Dismounting tool Bolted 3 bolts and some 4 bolts wheel bearing/hub

The tool is adjustable and designed to dismantle bolted wheel bearings with guides that usually rust in the wheel spindles. Extraction can be done with a full 22 ton directly on the vehicle, while the hub can also be dismantled in instances where this will be reused in the new bearing. On VW, Audi, Opel, Saab, Toyota etc. See page 18–19. Both press feet have two different sides, which are selected according to the vehicle/bearing design, adjustment is very easy. Designed and tested on the majority of 3 bolted wheel bearings, front and rear.

Press foot 01-00027-001 is used in pairs (01-00027-020) and can also be ordered separately for use in 01-00018 (dismounting tool for compact wheel bearings).

(Used with hub plate 01-00035-001, 002, 003, 004.)

Rec. cylinder 1090-02-WAL/01-00030.

Protected Design within EU - RCD No. 003477090-0001/0002
Patent Pending - European Patent Application No. EP16200076.4
US Design Patent Pending - US Patent Application No. 29/604 325

Parts in the set:

1. 2 pcs 01-00027-001 - Press foot
2. 01-00041-002 - Fixing plate
3. 2 pcs 01-00018-003 - Knob screw set
4. 2 pcs 01-00018-004 - Screw

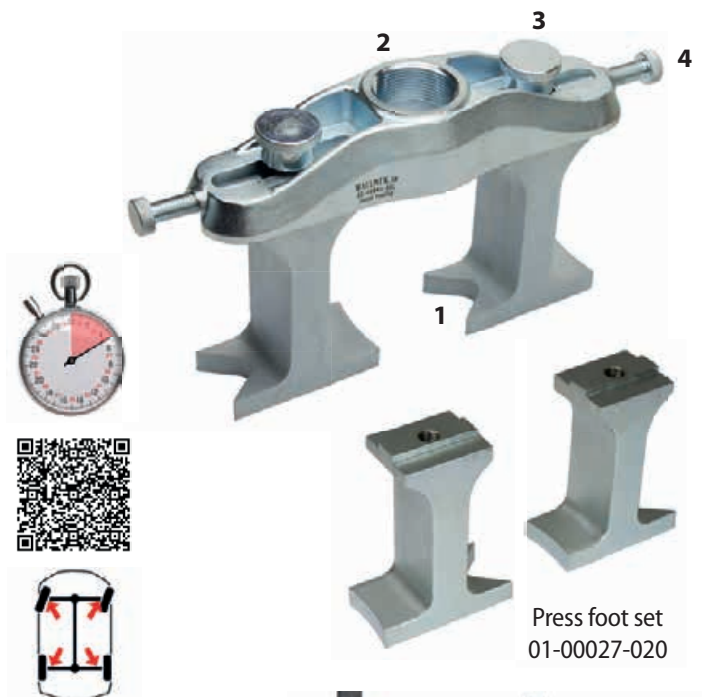

Press foot set
01-00027-020

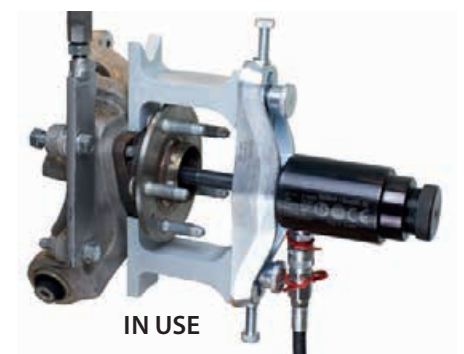

Generation 3

01-00047 Dismounting tool for 4 bolted wheel bearing/hubs with uneven brake shield

The tool is adjustable and designed for models with uneven brake shields with small press surfaces. The bolted wheel bearings with long guiding often get stuck due to corrosion. By pressing with the wrong tool, the knuckle can get damaged or even break. The following models are a few samples of where this tool is very useful; Subaru Forester, XV och Outback. Toyota Aygo och Avensis. Citroen C1, Peugeot 108, Opel Vectra och Zafira, Chrysler Voyager, Hyundai I10 and more. These models have uneven brake shields in the rear due to parking/emergency brake with drum brakes.

The dismounting can be made with up to 22 Ton directly on the car, also the hub can be dismounted if it needs to be reused in the new bearing. When the bearing has no center hole or the cv axle is still in the hub the tool is used with hub/bearing tool 01-00040 and 01-00042 for an easy operation. See page 18–19. The tool can also be used with press plates 01-00035-001, 002, 003, 004 in case of an open center hole in the bearing.

The press feet 01-00047-001 is used in pairs (01-00047-020).

Rec. cylinder 1090-02-WAL/01-00030.

Protected Design within EU - RCD No. 003477090-0001/0002
Patent Pending - European Patent Application No. EP16200076.4
US Design Patent Pending - US Patent Application No. 29/604 325

Parts in the set:

1. 1.2 × 01-00047-001 – Press foot
2. 01-00041-002 – Fixing plate
3. 2 × 01-00018-003 – Knob screw set
4. 2 × 01-00018-004 – Screw

NEW!



Press foot set
01-00047-020

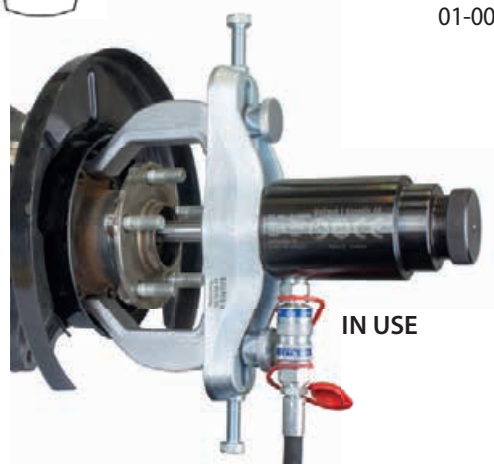

The press feet's get access to the small surfaces close to the bearing, pressing on the knuckle behind the brake shield.

Generation 3

01-00040 Hub-/bearing puller for wheel bearing dismounting 4/5 holes universal

The hub-/bearing puller makes bearing dismounting possible and easy when the hub axle is solid or when the axle shaft is still in the hub. The job is made directly on the car without time consuming dismounting. The puller is used with bearing dismounting tool 01-00026, 01-00027 or 01-00047 and with one of our hydraulic cylinders from 16 – 22 ton (max load 18 ton).

Bolt diameter: 4/5 holed – 92 – 131 mm. Slide hammer no. 1064 can be used as a manual solution, then together with adapter RES4029.

Rec. cylinder 1090-02-WAL/01-00030.

Protected Design within EU - RCD No. 003436518-0001/0002
US Design Patent Pending - US Patent Application No. 29/601 197



Parts in the set:

1. 01-00040-001 - Hub plate
2. 01-00040-002 - Carriage beam M22, 90 mm
3. 01-00040-003 - Carriage beam M22, 65 mm

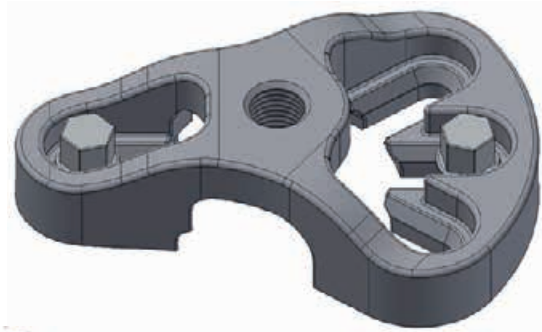
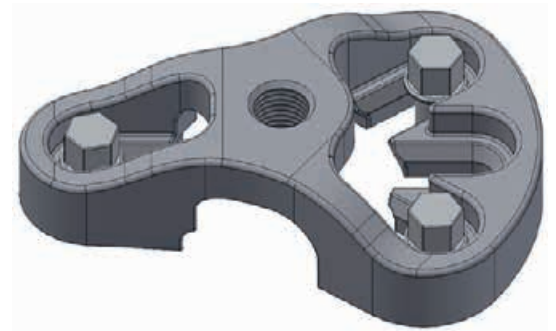
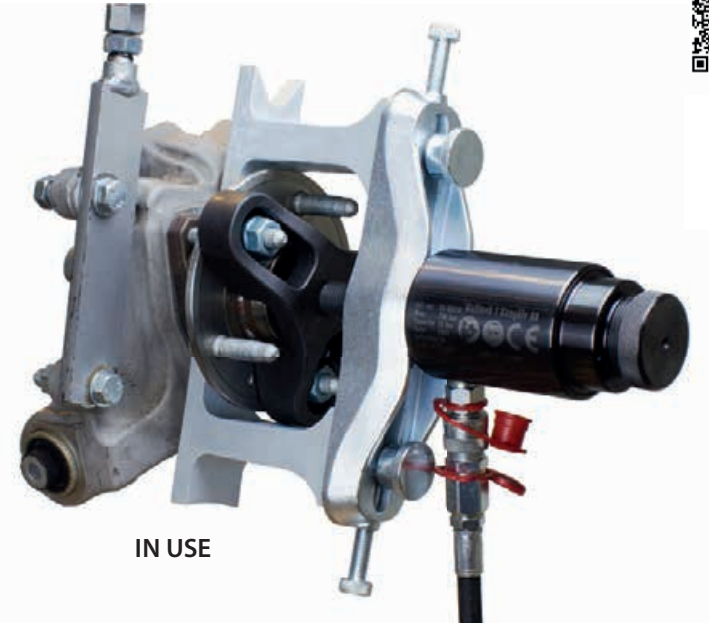

Generation 3

01-00042 Wheel bearing puller for 3 – 4 bolted bearings with dismantled hubs Suitable for VW, Audi, Seat, Skoda, Subaru e.t.c.

The bolted bearings can be rusted and stuck in the aluminum or steel knuckle. In many cases the old hub needs to be used also in the new bearing and has to be dismantled.

The tool is developed for time saving job directly on the car, in most cases also with the axle shaft still in the hub.

The hub/bearing tool 01-00040 is used (not included) when dismantling the hub.

With the bolts from the old bearing and the four washers in the set the fixture plate is mounted on to the bearing. Dismounting tool 01-00026, 01-00047 (4 bolt) or 01-00027 (3-4 bolt) is used as a press fixture when pressing out the stuck bearing. The job is made with one of our cylinders from 18 – 22 ton (max pressure 18 ton).

The sliding hammer 1064 can also be used as a manual solution with carriage beam RES4029.

Rec. cylinder 1090-02-WAL/01-00030.

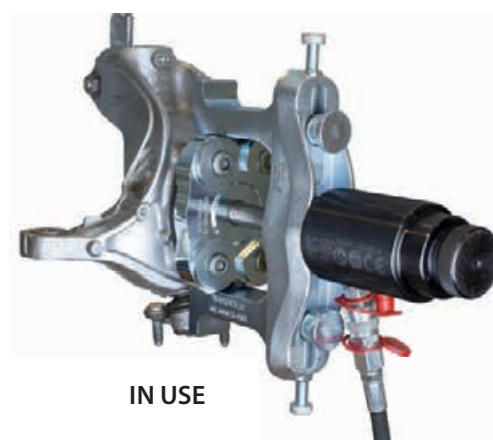

Parts in the set:

1. 01-00042-001 - Bearing puller plate
2. 4 pcs 01-00042-002 - Adjustment washer
3. 01-00042-003 - Carriage beam M22, 121 mm

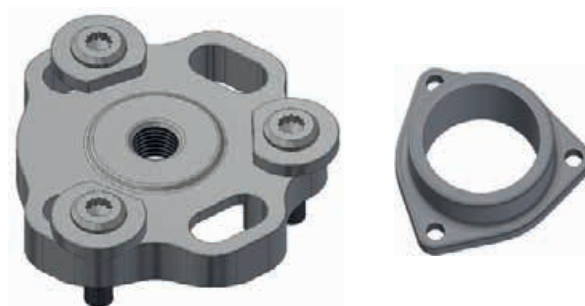

01-00042-010 Screw set Subaru rear wheel bearing

Wheel bearing dismounting rear on Subaru with 01-00042 requires longer bearing bolts. The bolts in the set (4 pcs) are M12x1,25x100 mm and fits in the bearing holders' thread.

The washers in 01-00042 are used with the flat side towards the bolt head.

Fit models: Legacy, Impreza, Forester, Outback, XV etc.

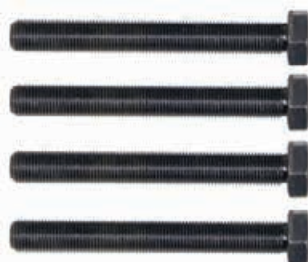

NEW!

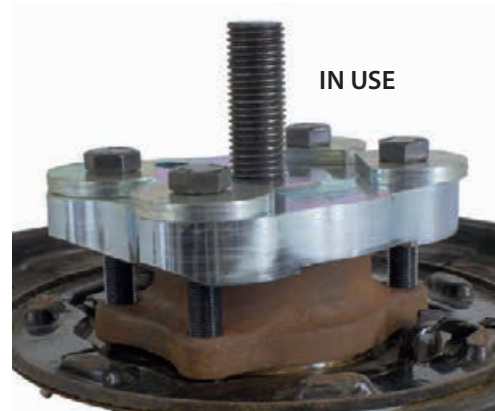

01-00024 Mounting set for BMW drive shafts, hydraulic

The drive shaft is easily mounted using an 8.5 ton hydraulic cylinder that draws the shaft into the right position.

Adaptors of high-strength steel for the shafts with M24x1.5 and M27x1.5 threads are included in the set, these are also available as accessories.

Parts in the set:

1. 01-00024-001 Adaptor for M24x1.5
2. 01-00024-002 Adaptor for M27x1.5
3. RES4027 Carriage beam M22, 250 mm
4. 01-00001-203 Press pipe 44.7 mm
5. 03-00015 Hydraulic cylinder 8.5 ton

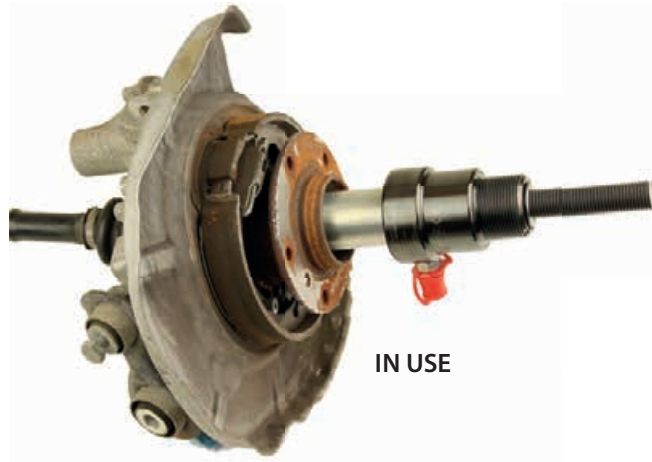

01-00024-010 Mounting set for BMW drive shafts, manual

The drive shaft is mounted manually using an M22 carriage beam and nut that draws the shaft into the right position. Adaptors of high-strength steel for the shafts with M24x1.5 and M27x1.5 threads are included in the set, these are also available as accessories.

Parts in the set:

1. 01-00024-001 Adaptor for M24x1.5
2. 01-00024-002 Adaptor for M27x1.5
3. RES4027 Carriage beam M22, 250 mm
4. 01-00001-203 Press pipe 44.7 mm
5. 01-00024-005 Thrust washer
6. RES4025 Flange nut M22

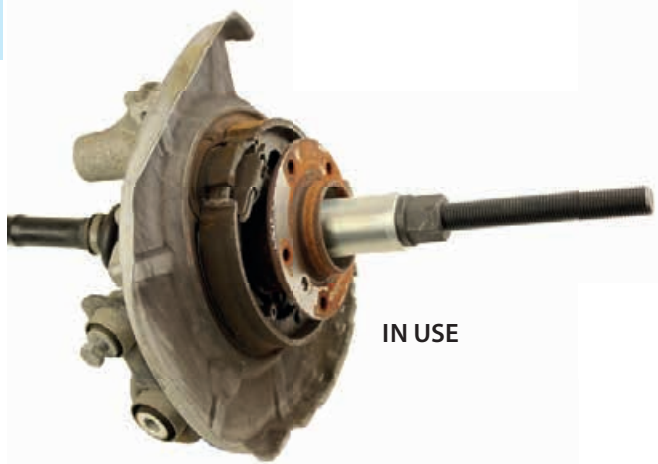

1090-30 Axle shaft tool 4 & 5 holes

This tool is specially developed for pressing out rusted & glued axle shafts directly on the car. This job only takes 5 min. The holes for the wheel bolts are oval to fit on almost all passenger cars with 4 & 5 holed hubs. With this equipment you avoid heating, splitting of the axle shaft or damage to other parts. Bolt on to the hub using the cars own wheel bolts, attach the cylinder, start pressing and for extra power fit a punching socket 1086-6 and then hammer on it. The tool can also be used for pulling wheel hubs with striking tool 1064 and adaptor 1068.

Rec. cylinder 1090-02-WAL/01-00030.

Bolt dia 4 hole – 92-120 mm / 5 hole – 98-131 mm.

For 6/8 bolted; see page 16, part.no. 01-00044.



IN USE

Parts in the set:

1. 1090-30-4 - Axle shaft tool, 4 holes
2. 1090-30-5 - Axle shaft tool, 5 holes



1064 Striking tool 5,2kg

Ergonomic slide hammer with 5,2 kg weight. Easy to get that extra force because of the side mounted handle. Very useful for dismounting the hub and brake disc at the same time. For use with hub set 1066 or adaptor 1068 for our axle shaft tool 1090-30.



1068 Adaptor from 1064 to 1090-30

Adaptor for using the striking tool 1064 with axle shaft tool 1090-30 for removal of wheel hubs.



1066 Hub set for 1064, dismounting

Set for hub dismounting with striking tool 1064.

Parts in the set:

1. 1090-20-02 - Hub plate 32mm*
2. 1090-20-04 - Hub plate 40mm*
3. 1090-20-06 - Hub plate 45mm*
4. 1090-20-08 - Hub plate 52mm*
5. RES4024 - Flange nut M18
6. RES4030 - Carriage beam M18, 150mm



*Inner Ø 20,25 mm

Wheel bearing and CV axle tools for 6-8 bolted hubs, SUV and Pickup.

Mitsubishi, Toyota, Nissan, Mazda, Dodge, Chevrolet, GMC, Ford (4x4) class 1-3 trucks.

01-00046-300 Universal wheel bearing set for 6-8 bolted hubs, 4x4. 01-00046, -45 and 44-030 in foam

A combined tool set for pressing out corroded CV axels and wheel bearings on Pick up's and SUV 150-350, 1500-3500 with 6 - 8 bolted hubs with up to 180 mm bolt diameter. The tools reduce the labor time considerable when working on brands like Mitsubishi, Toyota, Nissan, Mazda, Dodge, Chevrolet, GMC, Ford (4x4) etc.

Wheel bearings with or without center hole or with the CV axle still in the hub are dismantled directly on the vehicle without damaging the knuckle/spindle.

Delivered with foam for storage.

The tools are used with hydraulic cylinder 01-00030 (18T) or 1090-02-02 (22T).

Parts in the set:

1. 01-00046 – Dismounting tool for 3/4 bolted bearings
2. 01-00045 – Hub/bearing tool 6/8 bolt
3. 01-00044-030 – Set of 2 pressure feet inc. bolts and washers
4. 04-00022-015 – Foam for drawer 15

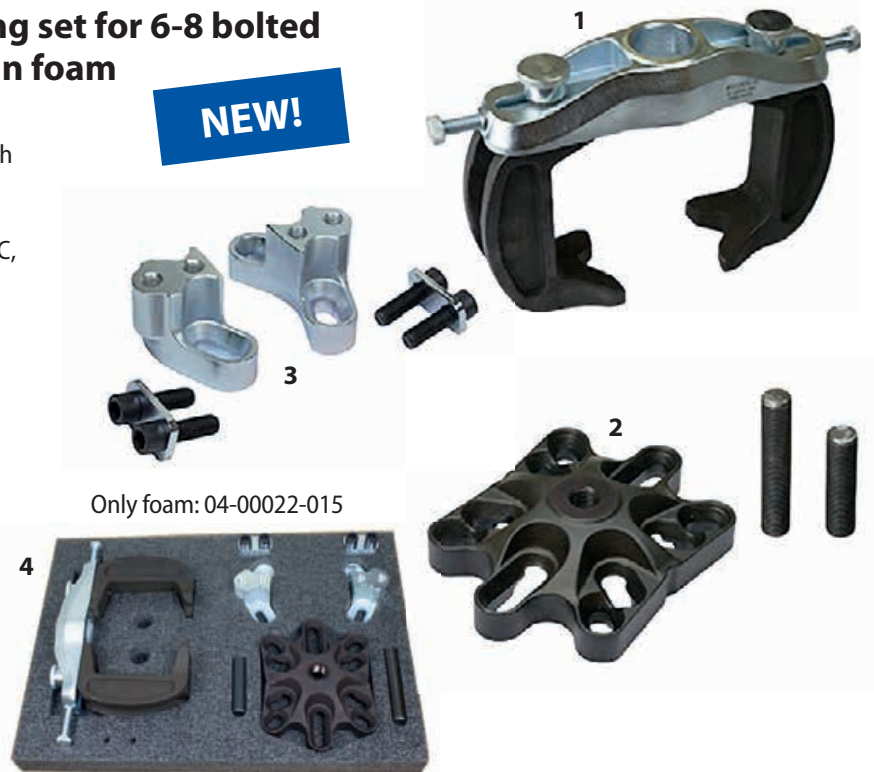

01-00044 Axle shaft, CV-joint tool 6/8 bolt

Adjustable tool for efficient axle shaft pressing for 6 & 8 bolted hubs. The design of the adjustable fixing plate in combination with the press feets covers;

Bolt pattern: 6 bolt 114 – 140 mm and 8 bolt 165 – 180 mm.

Mitsubishi, Toyota, Nissan, Mazda, Dodge, Chevrolet, GMC Ford (4x4) m.fl.

The tool allows 22 ton press force in combination with hammering when pressing out a rusted or glued axle shaft. The special hammering function creates a 3,5 time effect/force, heating of the car parts can then be avoided totally. The wheel bolts or nuts from the vehicle are used for bolting the tool on the hub.

The press feet set 01-00044-030 can be ordered separately for use in the following tools (with the updated fixture plate 01-00041-002); 01-00018, 01-00026, 01-00027, 01-00033 and 01-00037.

Rec. cylinder 1090-02-WAL/01-00030.

Protected Design within EU - RCD No. 003477090-0001/0002
Patent Pending - European Patent Application No. EP16200076.4
US Design Patent Pending - US Patent Application No. 29/604 325

Parts in the set:

1. 2 pcs 01-00044-001 - Press feet
2. 01-00041-002 - Fixing plate 1 1/2" gänga
3. 2 pcs 01-00041-003 - Sliding plate
4. 2 pcs 01-00018-004 - Screw
5. 4 pcs 01-00041-005 - Screw M14x45 10.9, insex

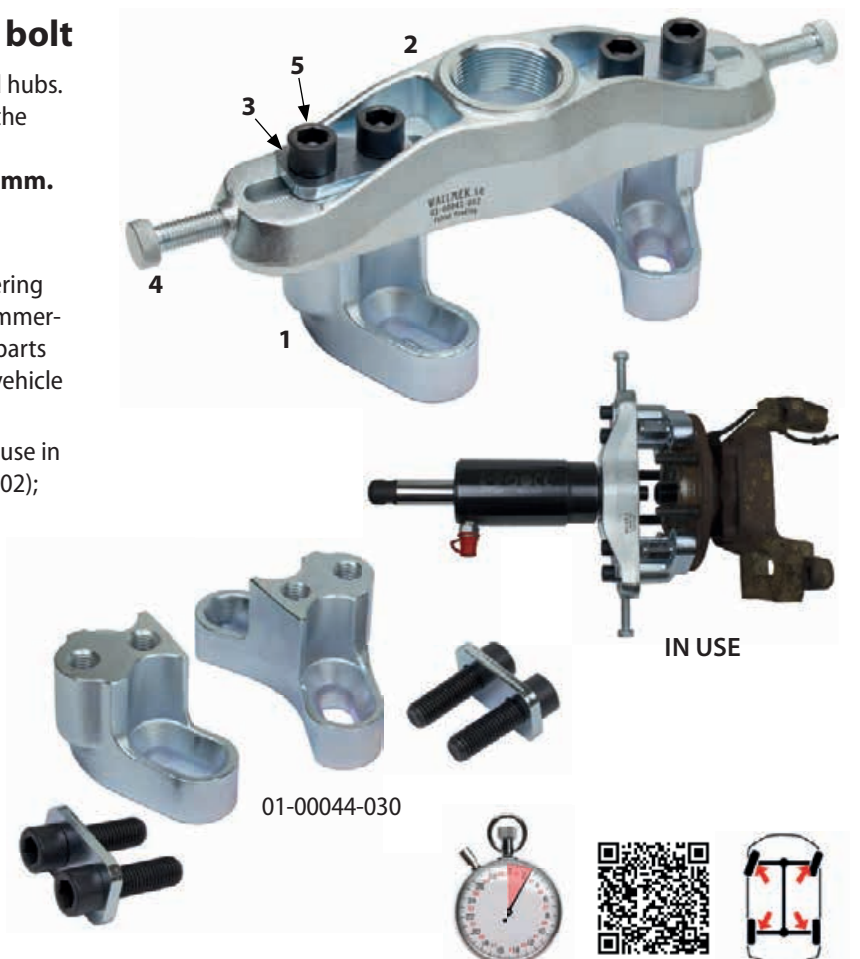

01-00045 Hub/Bearing puller for 6 – 8 bolted hubs

A problem solving tool for dismounting of bolted wheel bearing/hub units that are rusted and seized in the axle knuckle. In most cases the axle shaft can remain in the hub when the bearing is pulled out. This saves lots of time and is in many cases a must when working with Mitsubishi, Toyota, Nissan, Mazda, Dodge, Chevrolet, GMC Ford (4x4) etc.

Time consuming dismounting, heating and hammering can be totally avoided. The tool are bolted on with the wheel bolts/nuts on 6 – 8 bolted hubs and used together with the bearing puller 01-00046 directly on the car with no extra dismounting. The bearing is pulled out quick and easy with up to 22 ton.

Bolt diameter:

6 bolt 111,5 – 142,5 mm, 8 bolt 162,5 – 182,5 mm.

The M22 carriage beams in the set connects the tool to any of the following cylinders; 01-00030 or 1090-02-WAL.



Parts in the set:

1. 01-00045-001 - Hub plate 6/8 bolt
2. 01-00040-002 - Carriage beam M22, 90 mm
3. 01-00042-003 - Carriage beam M22. 10.9, 121 mm

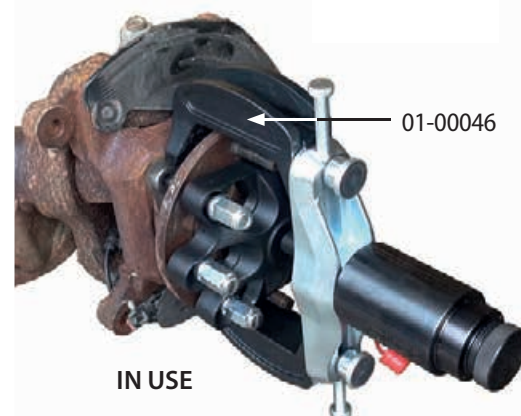

01-00046 Dismounting tool for 3 & 4 bolted wheel bearings on SUV/US models with 6 & 8 wheel bolts

Bolted wheel bearings with deeper fittings in aluminum or steel axle knuckle are often seized badly with rust after a few years. Instead of destroying the parts by heating and hammering or cracking it in the shop press the bearing can quick and easy be pressed out directly on the vehicle with this new dismounting tool. It can be used with only a hydraulic cylinder when the axle shaft is removed. It can also be used with a special hub plate 01-00045 when the axle shaft still is located in the hub. This will save lots of time and are in many cases a must (Dodge, Chevrolet, GMC and Ford Pickup truck).

The design of the press feet's allows access on both 3 and 4 bolted wheel bearings on SUV and Pickup trucks (Mitsubishi, Toyota, Nissan, Mazda, Dodge, Chevrolet, GMC Ford (4x4) etc) The adjustable fixing plate in combination with design of the press feet's makes it possible to dismount also the largest hubs, up to 245 mm.

The two press feet's can also be ordered as a pair in set; 01-00046-020.

Rec. cylinder 1090-02-WAL/01-00030.

Parts in the set:

1. 2 pcs 01-00046-001 - Press foot
2. 01-00041-002 - Fixing plate
3. 2 pcs 01-00018-003 - Knob screw set
4. 2 pcs 01-00018-004 - Screw



01-00046-020

01-00045

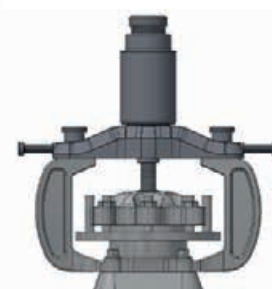
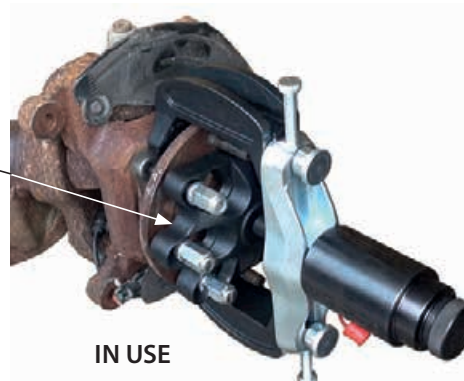

Wheel bearing sets for light commercial vehicles

See each set for recommended cylinder.

1091-15 Wheel bearing set, rear for Citroën Jumper, Fiat Ducato & Peugeot Boxer

Set for replacing rear wheel bearings. The wheel bearing is replaced directly on the car with minimum dismantling. The bearings and hubs on these chassis often need the power of 32 ton combined with punching force to separate. Also the Axle shaft press is designed to fit all 5 holed hubs on commercial vehicles.

Rec. cylinder 03-00028.



Parts in the set:

1. 1090-15-B - Press socket
2. 1091-15-01 - Adaptor ring
3. 1091-17-04 - Bearing plate*
4. 1091-17-07 - Hub plate*
5. 1091-28 - Axle shaft tool, 5 holes, lkw

*Inner Ø 23 mm



1091-17 Wheel bearing set, front for Citroën Jumper, Fiat Ducato & Peugeot Boxer

The wheel bearing is replaced directly on the car with minimum dismantling. The bearings and hubs on these chassis often need the power of 32 ton combined with punching force to separate. Est.time: 30-40 min/side.

Rec. cylinder 03-00028.



Parts in the set:

1. 1091-17-01 - Press ring
2. 1091-17-02 - Press plate
3. 1091-17-03 - Press pipe
4. 1091-17-05 - Bearing plate*
5. 1091-17-06 - Holder*
6. 1091-17-08 - Press pipe
7. 1091-17-09 - Hub plate*

*Inner Ø 23 mm



Used with (not included):

- 1091-17-04 - Bearing plate (included in 1091-15)
- 1091-17-07 - Hub plate (included in 1091-15)

1091-18 Press ring for Citroën Jumper, Fiat Ducato & Peugeot Boxer 2007-

Is used instead of 1091-17-01 together with set 1091-17 on cars newer than 2007.



NEW!

02-00012 Rear wheel bearing set Peugeot Expert (Traveller), Citroën Jumpy (Spacetourer) och Toyota Proace (Proace Verso) 2016 -

The rear wheel bearing is replaced directly on the car without time consuming dismounting. This bearing is a 92 mm compact type, also called HBU 2.1 or generation 2. These bearings get internal damages when mounting incorrect by pressing on the hub. Only the outer bearing race is supposed to be used for correct mounting. The set is designed to demount the bearings also with solid (without hole) hubs and mounting the new bearing with open hub for the CV axle.

Mounting ring 1090-25-15 gives a correct position towards the bearing during mounting. The majority of the parts in the set is used for all other compact bearings on the market. The set also comes with a 300 mm M22/20 carriage beam with a nut, required when using the 18 Ton cylinder 01-00030. Note that the bearing needs to be pressed twice with the 18 ton cylinder for a correct mounting. Rec. cylinder 1090-02-WAL/01-00030.

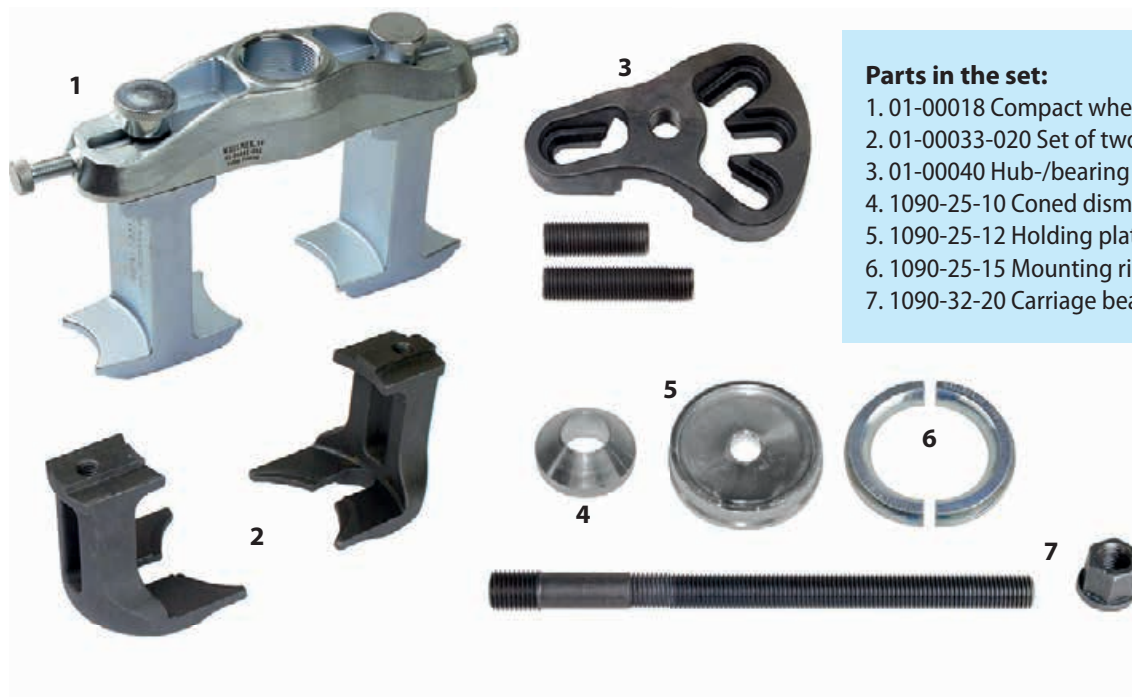

Parts in the set:

1. 01-00018 Compact wheel bearing dismounting tool
2. 01-00033-020 Set of two pressure feet 01-00033-001
3. 01-00040 Hub-/bearing puller
4. 1090-25-10 Coned dismounting plate
5. 1090-25-12 Holding plate VW T5
6. 1090-25-15 Mounting ring Peugeot, Citroën and Toyota
7. 1090-32-20 Carriage beamset M20

Dismounting

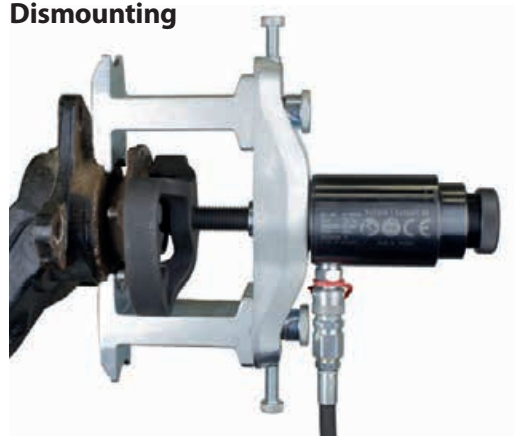

Mounting

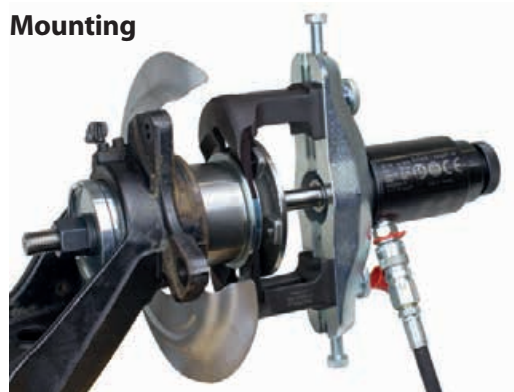

1091-10 Wheel bearing set, front Ford Transit 2000-

The wheel bearing is replaced directly on the car with minimum dismounting. Also makes it possible to change a brake disc without dismounting the wheel bearing. **The set covers both sizes of Ford Transit, 78 mm and 87,5 mm.**

Rec. cylinder 03-00028.



Parts in the set:

1. 1090-26-01 - Large press plate, double sided
2. 1090-26-02 - Large press pipe
3. 1091-10-04 - Hub plate*
4. 1091-11 - Hub tool
5. 1091-17-04 - Bearing plate*
6. 1091-17-08 - Press pipe

Note that 1090-26-01 and 1090-26-02 exist as own kit 1080-26.

*Inner Ø 23 mm



02-00008 Wheel bearing set, rear Ford Transit

Puller set for Ford Transit rear wheel bearing. The tool can also be used in front when pressing out axle shafts from the hub.

The nuts in the set are special made to fit Ford Transit M14×2 thread.

The puller can be fitted on most five holed hubs, with other or original nuts.

Rec. cylinder 03-00028.



Parts in the set

1. 5 pcs 04-00007-004 - Special nuts M14×2
2. 1091-28 - Axle shaft tool, 5 hole, lkww



02-00011 Wheel bearing set Iveco Daily 35 2014 –

The set makes it possible to replace the bearing directly on the vehicle with up to 32 ton pressure, total time only 30 – 40 min. ABS sensors, ball-joints e,t,c are left untouched with the use of a hydraulic cylinder.

The special designed press ring that is mounted behind the hub prevents any severe damage or bending in the wheel knuckle during hub dismounting. The set can also prepare the lock ring before dismounting. The set can also be used in the garage press when a cylinder is missing. Rec. cylinder 03-00028.

Protected Design within EU - RCD No. 003995240-0001/0002

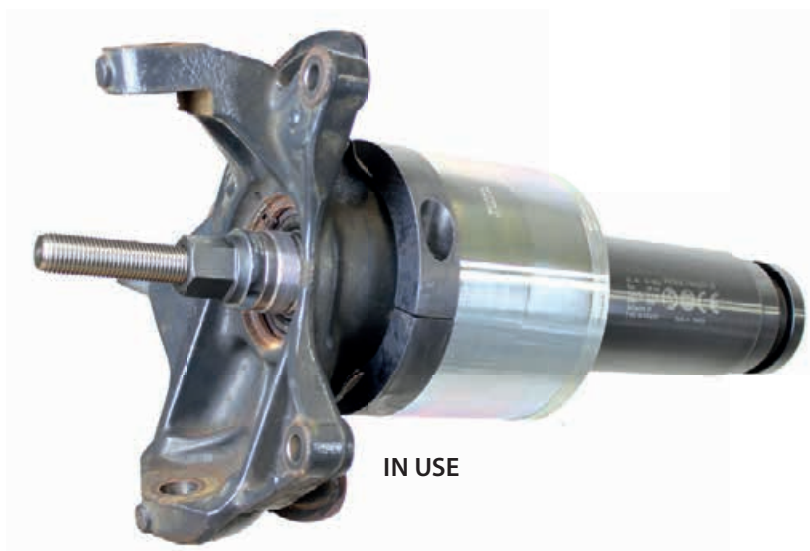

Parts in the set:

- | | |
|-------------------------------|----------------------------------|
| 1. 02-00011-001 - Press ring | 5. 02-00011-005 - Bearing socket |
| 2. 02-00011-002 - Press pipe | 6. 1091-17-02 - Press plate |
| 3. 02-00011-003 - Press plate | 7. 1091-17-05 - Bearing plate |
| 4. 02-00011-004 - Hub plate | 8. 1091-17-08 - Press pipe |

1091-27 Hub puller for Iveco Daily 29-50

Tool for dismounting the wheel bearing/hub on Iveco Daily models 29-50.
Rec. cylinder 1090-02-WAL/01-00030.



Parts in the set:

1. 3 pcs 1091-18-03 - Bolt M14x40
2. 1091-27-01 - Plate

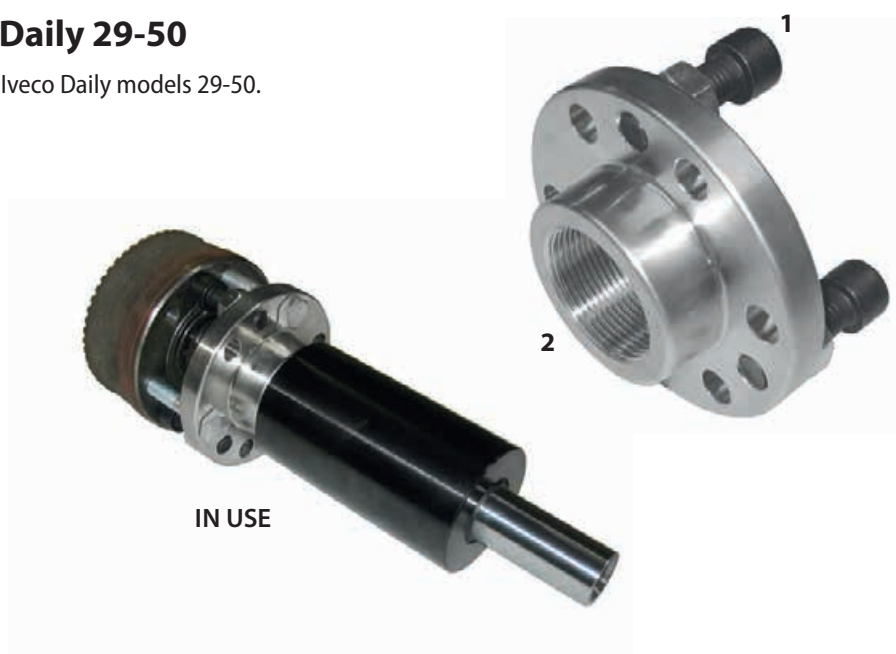

02-00006 Wheel bearing set rear MB Vito & Viano

Set for replacing of rear wheel bearings on Mercedes-Benz Vito and Viano 2003–2010 (W639). The bearings are replaced directly on the car without unnecessary dismantling.

The parts are designed to protect the ABS sensor from getting damaged and to install the lock ring at the same time as the bearing. Est.time: 30 min/side.

Rec. cylinder 1090-02-WAL/01-00030.

Parts in the set:

1. 1090-20-06 - Hub plate 45mm*
2. 1090-20-BX - Press plate for 1090-20-R4
3. 1090-20-R1 - Press pipe
4. 1090-20-T10 - Bearing plate 63mm*
5. 1090-20-T16 - Bearing plate 77,8mm*
6. 1090-22 - Press clamp, axle shaft & hub
7. 1090-25-12 - Bearing plate*
8. 3 pcs 1091-21-04 - Spacer bolt rear

*Inner Ø 20,25 mm

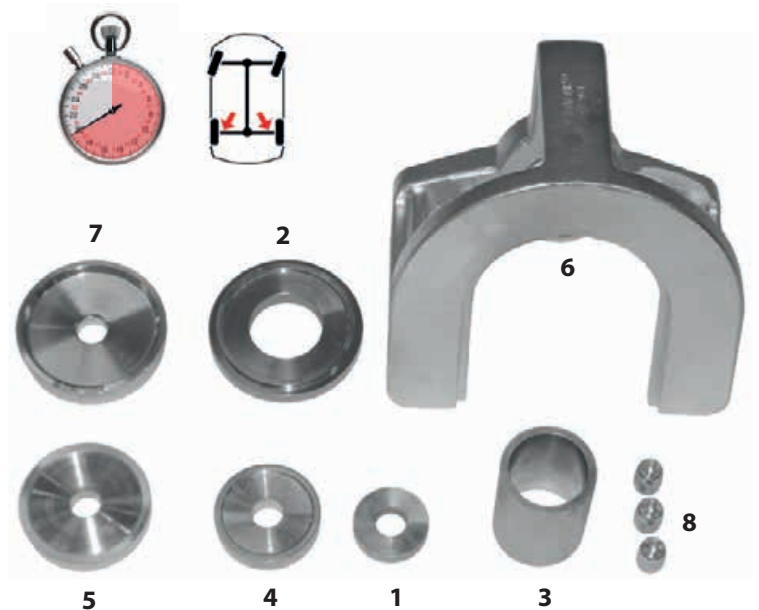

1091-28 Axle shaft tool, 5 holes, light commercial vehicles

This tool is specially developed for pressing out rusted and glued axle shafts directly on the vehicle. This job only takes 5 min. The holes for the wheel bolts are oval to fit on all light commercial vehicles with 5 holed hubs. With this equipment you avoid heating, splitting of the axle shaft or damage to other parts. Bolt on to the hub using the cars own wheel bolts, mount the cylinder, start pressing and for extra power fit a punching socket 1086-6 and then hammer on it.

Bolt dia 119-172 mm.

Included in set 1091-15 and 02-00008.

Rec. cylinder 03-00028.



IN USE



04-00007-001 Special bolt nut M16x1,5

Designed to be used with axle shaft tool 1091-28 when pressing axles or rear wheel bearings. Fits Peugeot Boxer, Citroën Jumper, Fiat Ducato, Renault Master and more. (5 pcs needed).



04-00007-004 Special nut M14x2

Designed to be used with axle shaft tool 1091-28 when pressing axles or rear wheel bearings. Fits Ford Transit. (5 pcs needed).



1091-22 Wheel bearing set, front Renault Trafic, Opel Vivaro 2002- & Nissan Primastar

Set for replacing front wheel bearings. The wheel bearing is replaced directly on the car with minimum dismounting.

Rec. cylinder 1090-02-WAL/03-00028/01-00030.

Parts in the set:

1. 1090-20-M - Holder*
2. 1090-20-R1 - Press pipe
3. 1090-20-T18 - Bearing plate 82,9mm*
4. 1090-20-T20 - Bearing plate 87,8mm*
5. 1091-10-04 - Hub plate**
6. 1091-17-02 - Press plate
7. 1091-17-03 - Press pipe
8. 1091-22-01 - Bearing plate 57mm**

*Inner Ø 20,25 mm ** Inner Ø 23 mm

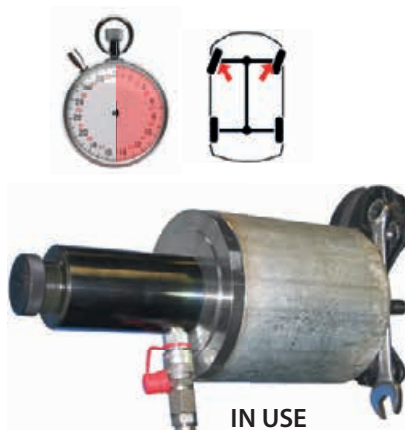

1091-23 Wheel bearing set, front Renault Master, Opel Movano 2003-2010 & Nissan Interstar

Set for replacing front wheel bearings. The wheel bearing is replaced directly on the car with minimum dismounting.

Rec. cylinder 03-00028.

Parts in the set:

1. 1091-10-04 - Hub plate*
2. 1091-17-02 - Press plate
3. 1091-17-03 - Press pipe
4. 1091-17-04 - Bearing plate*
5. 1091-17-08 - Press pipe
6. 1091-23-01 - Press ring
7. 1091-23-02 - Bearing cup
8. 1091-23-03 - Press plate*
9. 1091-23-04 - Press plate*

*Inner Ø 23 mm



02-00010 Front wheel bearing set Renault Master Nissan Interstar & Opel Movano 2010 -

Set for replacing front wheel bearings. The wheel bearing is replaced directly on the car with minimum dismounting. If earlier set 1091-23 is in use, only 02-00010-001 and 1091-18 is required for models after 2010.

Rec. cylinder 03-00028.

Parts in the set:

1. 02-00010-001 - Presssocket
2. 1091-10-04 - Hub plate*
3. 1091-17-02 - Press plate
4. 1091-17-03 - Press pipe
5. 1091-17-04 - Bearing plate*
6. 1091-17-08 - Press pipe
7. 1091-18 - Press ring
8. 1091-23-03 - Press plate*

*Inner Ø 23 mm

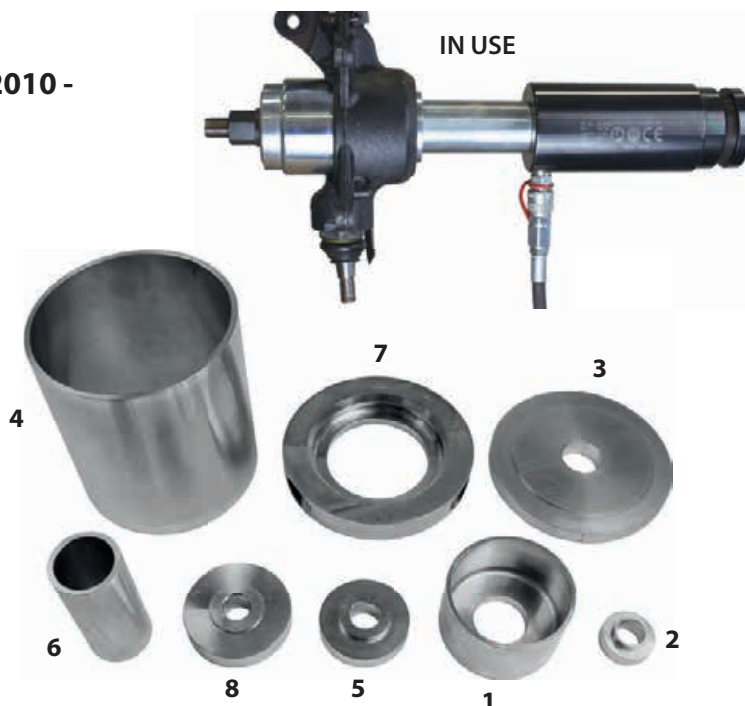

Ball-joint and bushing sets

Used with press block 1090-60 and hydraulic cylinder 1090-03, 01-00030 or 1090-02-WAL.

1090-60 Press block

Strong and flexible press block for replacing of ball-joints, bushings and more. Can also be equipped with 1090-60-05 (open side) to become a 1090-69.

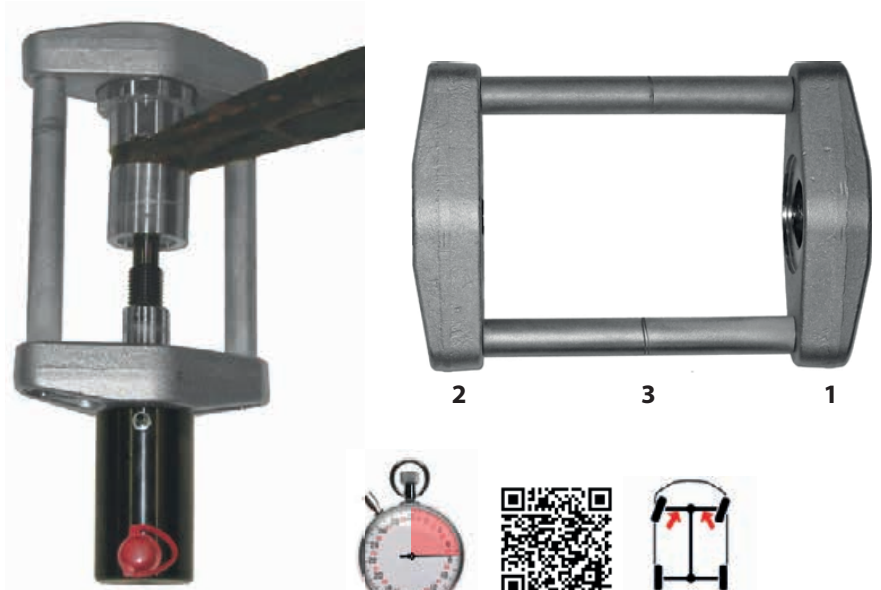

IN USE

Consists of:

1. 1090-60-01 - Plate with thread
2. 1090-60-02 - Plate w/o thread
3. 2 pcs 1090-60-03 - Support rod
4. 4 pcs 1090-60-04 - Bolt M16x40mm

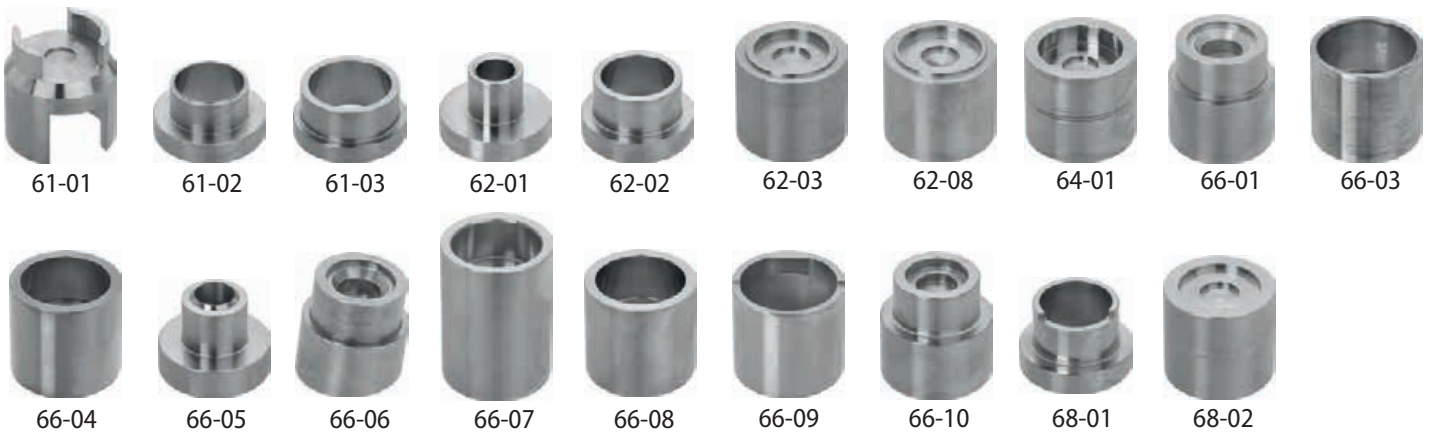

Brand specifications for ball-joint tools

Car model	Part no
BMW E30, E36 (inner)	1090-62-01, 1090-62-02, 1090-62-03
BMW E36 outer	1090-61-01, 1090-61-02, 1090-61-03
MB 124	1090-62-01, 1090-62-02, 1090-64-01
MB Sprinter	1090-66-01, 1090-66-03
MB Sprinter 2007-	1090-66-08, 1090-66-09, 1090-66-10
Dacia Logan I (2006-2013), Renault Clio III (2006-2013), Renault Grand Scenic I (2003-2009), Renault Laguna I, Renault Megane II, Renault Modus (2005-2013), Renault Senic II	1090-62-01, 1090-68-01, 1090-68-02
Nissan Interstar, Opel Movano, Renault Master	
Upper:	1090-66-04, 1090-66-06
Lower:	1090-62-08, 1090-66-04, 1090-66-05
VW T4	1090-66-01, 1090-66-04
VW LT 35	1090-66-01, 1090-66-03
VW Crafter	1090-66-08, 1090-66-09, 1090-66-10
Hyundai Trajet, Santa Fe	1090-66-05, 1090-66-07, 1090-68-01

Dismounting suspension arm



04-00024

See info page 1

03-00030

See info page 43

MB Sprinter – VW Crafter – Ford Transit

Used with press block 1090-69 and hydraulic cylinder 1090-03, 01-00030 or 1090-02-WAL.

1090-69 Press block, open plate

Strong and flexible press block for replacing of ball-joints, bushings and more. Can also be equipped with 1090-60-02 to become a 1090-60.

Consists of:

1. 1090-60-01 - Plate with thread
2. 2 pcs 1090-60-03 - Support rod
3. 4 pcs 1090-60-04 - Bolt M16x40mm
4. 1090-60-05 - Plate with open side



IN USE

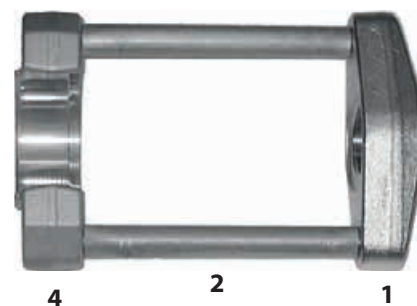

1090-60-06 Adaptor plate

For mounting in press block 1090-69. The adaptor gives the same measure in the bottom part as the closed press block 1090-60.



IN USE



1090-39 Suspension bushing set, rear for Audi A3, Seat Ibiza, Skoda Fabia & VW Golf IV

Set for replacing the rear suspension bushings quick & easy . The set is used with a press block 1090-69 instead of using a fragile threaded bolt through the bushing when dismantling. 1090-69 is not included in set.



IN USE



Parts in the set:

1. 1090-39-10 - Press pipe
2. 1090-39-06 - Dismounting cup
3. 1090-39-08 - Mounting cup
4. 1090-39-09 - Mounting ring

Volkswagen	Audi	Seat	Skoda
Beetle (I) 1998-2010	A3 (8L) 1997-2003	Ibiza (III) 2002-2009	Fabia (I) 2002-2008
Bora 1998-2005	TT 1999-2006	Leon (I) 1999-2006	Ocative (I) 1998-2010
Golf (IV) 1997-2008		Toledo (II) 1999-2005	Roomster 2006-
Polo (IV) 2002-2012			Rapid 2012-
Fox 2003-			

Used with cylinders 01-00030, 1090-02-WAL or 1090-03.

01-00022 Bushing set for replacement of the front bushing on the rear trailing arm on Volvo S60, S80, V60, V70, XC60 and XC70 2007- Ford Mondeo, S Max, Galaxy 2007-

Using the tool the rear suspension bushing can be replaced directly on the vehicle with a minimum of dismantling. Only takes 30 minutes per side. The exposed position of the bushing results in rust and difficulty in removing, the recommended cylinders are from 14 - 22 ton and are screwed in to the press block.

Do not load the block or bushing with more than 16 ton!!



Parts in the set:

1. 01-00022-020 - Press fixture
2. 01-00022-003 - Press pipe
3. 01-00022-004 - Thrust washer
4. 01-00022-005 - Adaptor ring
5. 1090-60-01 - Plate with thread
6. 2 x 1090-60-04 - Bolt M16x40mm



01-00022-010 Bushing set for existing blocks

When press block 1090-60 or 1090-69 is already owned, 01-00022-010 can be ordered instead. The threaded block section is then fitted on the tool to be used, see 01-00022.

Parts in the set:

1. 01-00022-020 - Press fixture
2. 01-00022-003 - Press pipe
3. 01-00022-004 - Thrust washer
4. 01-00022-005 - Adaptor ring



IN USE



1090-69-20-B Supporting arm bushing set, rear Volvo V50/S40/C30 2004 -, Ford Focus 1999 -, Mazda 3 2003 - 2013, Ford Kuga 2008 -

Set for quick exchanging of front bushing in rear supporting arm. Est.time: 20 min/side. This version also covers Ford Kuga 2008 -. The set is used with bushing set 01-00022 or press block 1090-69.



Parts in the set:

1. 1090-69-21 - Dis-/mounting socket
2. 1090-69-22 - Mounting plate
3. 1090-69-23 - Holding ring
4. 1090-69-24 - Press plate
5. 1090-69-25 - Mounting socket
6. 1090-69-26 - Holding ring

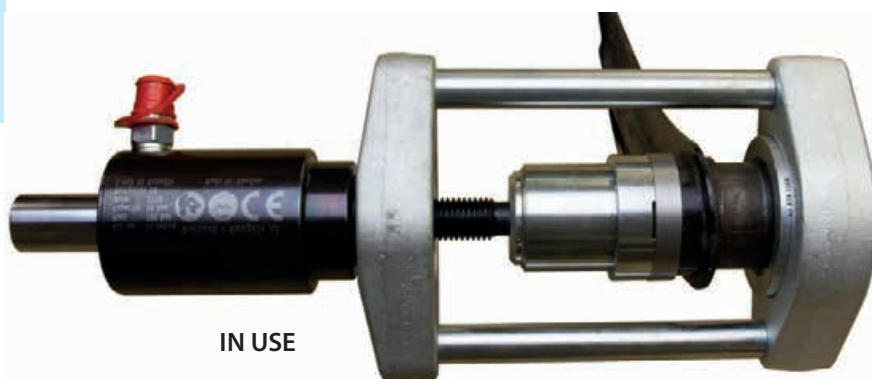

IN USE

Used with press block 1090-55 and hydraulic cylinder 1090-03, 01-00030, 1090-02-WAL or 03-00015.

1090-55-B Press block, max 16 ton

This forged press block allows access to change the ball-joints and sway arm bushings on Mercedes-Benz 211 and 220. No further reinforcement is necessary, even when pressing with 16 ton.



02-00009 Ball-joint set Ford Transit 2000-

A set for quick and easy replacement of ball-joints on Ford Transit. The work is made directly on the car with a minimum of dismounting.



Parts in the set:

- 1. 02-00009-001 press pipe
- 2. 02-00009-002 Lid
- 3. 02-00009-003 Mounting socket
- 4. 02-00009-004 Dismounting socket



1090-54-10 Ball-joint set for MB 211 & 220

Set for replacing ball-joints on Mercedes-Benz 211 and 220. No need for dismounting of brake components or reprogramming of the onboard computer.

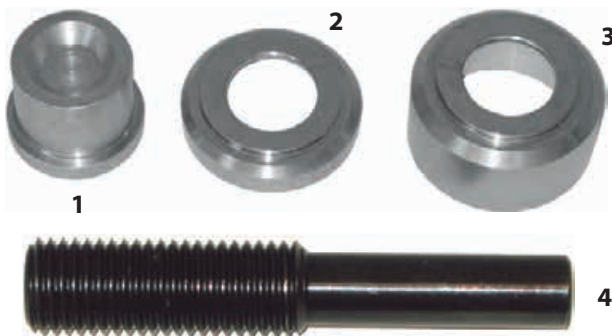

Parts in the set:

- 1. 1090-54-03 - Press socket MB 211, 220
- 2. 1090-54-04 - Mounting socket MB 211, 220
- 3. 1090-54-05 - Dismounting socket MB 211, 220
- 4. RES 1090-01-12 - Adjustable press rod 132mm, M24

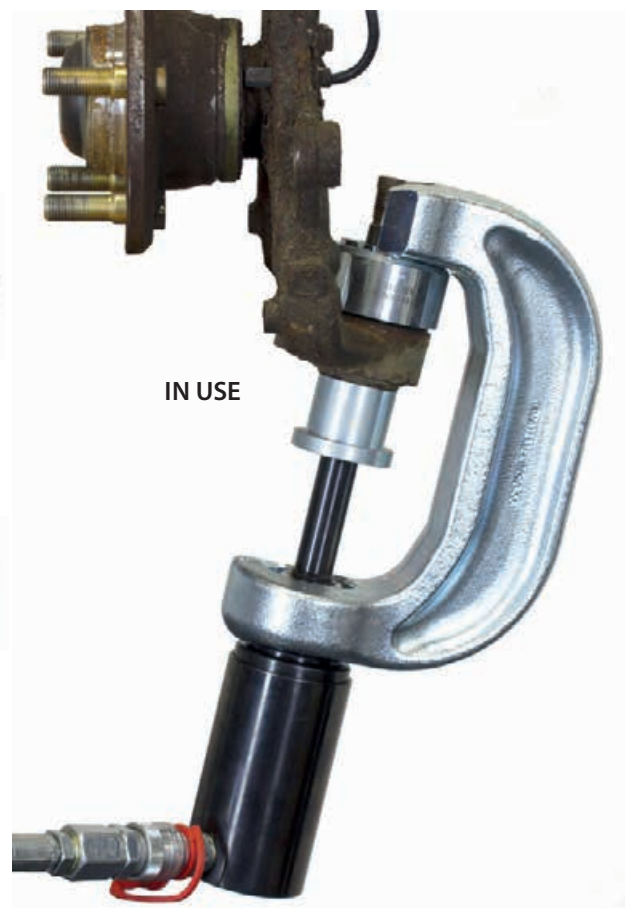

1090-54-11 Sway bar ball-joint set for MB 211 & 220

Set for replacing sway bar ball-joints on Mercedes-Benz 211 and 220. The only parts you have to dismount is the sway bar itself. No need for dismounting of shock absorbers or lower slewing bracket fittings.



1



2



Parts in the set:

1. 1090-54-01 - Press socket MB 211, 220
2. 1090-54-02 - Press socket MB 211, 220

1090-54-06 Ball-joint dismounting socket for Mercedes-Benz ML

Socket for dismounting ball-joints on Mercedes-Benz ML. Is used with 1090-54-10.



1090-54-12 Suspension arm bushing set, rear for MB C, E and S class

Set for replacing of rear, lower bushing in rear suspension arm.

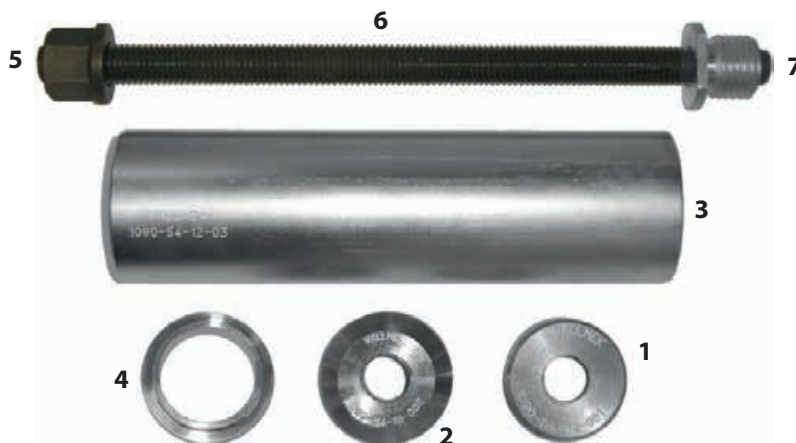

Parts in the set:

1. 1090-54-12-001 - Dismounting socket
2. 1090-54-12-002 - Mounting socket
3. 1090-54-12-003 - Press pipe
4. 1090-54-12-004 - Holding ring, mounting
5. RES4021 - Flange nut M14
6. RES4016 - Carriage beam M14, 250mm
7. RES4010 - Adaptor M22-M14



IN USE

01-00009 Silent bushing set rear BMW E60-65 & E90, complete set

Set for replacing rear silent bushings on (5, 6, and 7 ser) and (1 and 3 ser). No need for dismounting of anything else then the bushings own bolts.



Parts in the set:

- | | | |
|-----|--------------|------------------------------|
| 1. | 1090-18-E5 | Press pipe Touring |
| 2. | 1090-18-E6 | Press plate Touring |
| 3. | 1090-18-D5 | Mounting plate E38 & E39 |
| 4. | 1090-15-B | Press socket |
| 5. | 1090-15-C | Press plate |
| 6. | 1090-15-B3 | Holding ring E32 & E34 |
| 7. | 1090-14-B6 | Holding ring |
| 8. | 1090-14-D6 | Mounting plate |
| 9. | RES4026 | Carriage beam M18/M22, 250mm |
| 10. | RES4029 | Carriage beam M18/M22, 180mm |
| 11. | 01-00009-001 | Mounting ring |
| 12. | 01-00009-002 | Holding ring |
| 13. | 01-00009-003 | Threaded plate |
| 14. | 01-00010-001 | Threaded plate |
| 15. | 01-00010-002 | Press plate |
| 16. | 01-00010-003 | Holding ring |
| 17. | 01-00010-004 | Mounting ring |
| 18. | 01-00011-001 | Threaded plate |
| 19. | RES4010 | Adaptor M22-M14 |
| 20. | RES4016 | Carriage beam M14, 250mm |
| 21. | 1090-15-D | Holding plate E32 & E34 |



01-00009-101 Silent bushing set,

Included in 01-00009. Add on set for BMW E60-65 and E90. Use with 1090-14-10, 1090-15, 1090-18 and 1090-19.

- | | | |
|-----|--------------|--------------------------|
| 11. | 01-00009-001 | Mounting ring |
| 12. | 01-00009-002 | Holding ring |
| 13. | 01-00009-003 | Threaded plate |
| 14. | 01-00010-001 | Threaded plate |
| 15. | 01-00010-002 | Press plate |
| 16. | 01-00010-003 | Holding ring |
| 17. | 01-00010-004 | Mounting ring |
| 18. | 01-00011-001 | Threaded plate |
| 19. | RES4010 | Adaptor M22-M14 |
| 20. | RES4016 | Carriage beam M14, 250mm |
| 21. | 1090-15-D | Holding plate E32 & E34 |

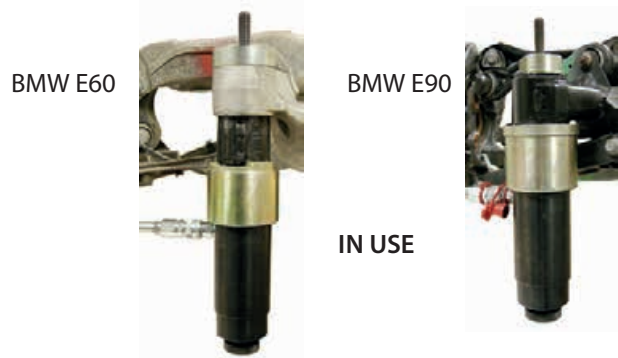

1090-16-10 Ball-joint/bushing set lower rear BMW E38/39/60/63/64/65/66/52/53

The steel bushing is replaced directly on the car, break disk etc is not needed to dismount. These parts are also included in set 1090-16, see list above. RES4010, RES4016 and RES4021 are included in the set.



Used with cylinders 01-00030 or 1090-02-WAL.

1090-15 Silent bushing set, rear for BMW E28, E30, E32 & E34

Set for replacing rear silent bushings. No need for dismantling of the rear axle.

1090-19 Used with 1090-18 for E38 and E39.

Parts in the set:

1. 1090-15-A1 - Threaded plate E30
2. 1090-15-A2 - Threaded plate E28
3. 1090-15-A3 - Threaded plate E32 & E34
4. 1090-15-B - Press socket (included in 1090-19)
5. 1090-15-B1 - Holding ring E30
6. 1090-15-B2 - Holding ring E28 (included in 1090-19)
7. 1090-15-B3 - Holding ring E32 & E34 (included in 1090-19)
8. 1090-15-C - Press plate
9. 1090-15-D - Holding plate E32 & E34
10. 1090-15-D1 - Mounting ring E30
11. 1090-15-D2 - Mounting ring E28

Used with following (not included):

- RES4010 - Adaptor M22-M14
- RES4016 - Carriage beam M14, 250 mm

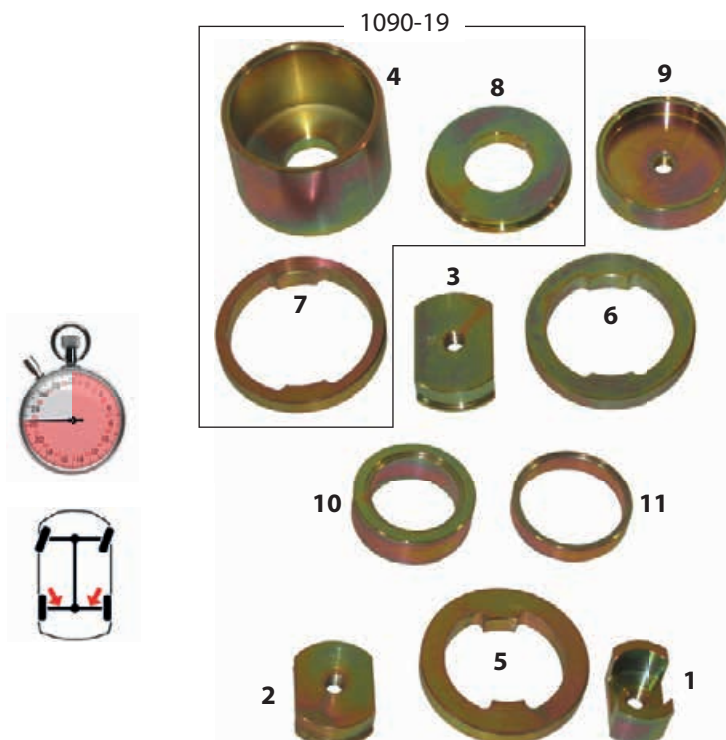

1090-18 Silent bushing set, rear for BMW E38 & E39, including touring

Set for replacing rear silent bushings on BMW E38 and E39, including touring. (use with set 1090-15 or 1090-19). No need for dismantling of anything else then the bushings own bolts.

Parts in the set:

1. 1090-18-A5 - Threaded plate
2. 1090-18-B5 - Holding ring
3. 1090-18-D5 - Mounting plate E38 & E39
4. 1090-18-E5 - Press pipe Touring
5. 1090-18-E6 - Press plate Touring
6. RES4026 - Carriage beam M18/M22, 250mm
7. RES4029 - Carriage beam M18/M22, 180mm

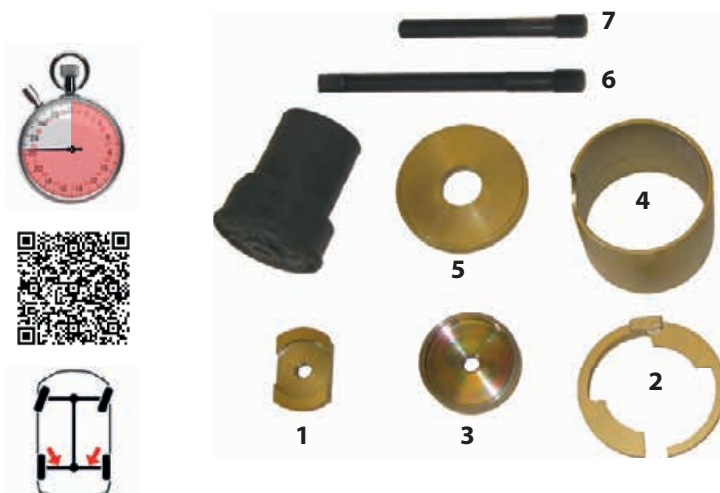

1090-14 Silentbushing set, rear for BMW X5, E53

Set for replacing rear silentbushings on BMW X5, E53.

1090-14-10 Used with 1090-18 for X5, E53 silent bushing.

Parts in the set:

1. 1090-14-A6 - Threaded plate (included in 1090-14-10)
2. 1090-14-B6 - Holding ring (included in 1090-14-10)
3. 1090-14-D6 - Mounting plate (included in 1090-14-10)
4. 1090-15-B - Press socket
5. 1090-15-C - Press plate
6. 1090-18-E5 - Press pipe Touring
7. 1090-18-E6 - Press plate Touring
8. RES4026 - Carriage beam M18/M22, 250mm

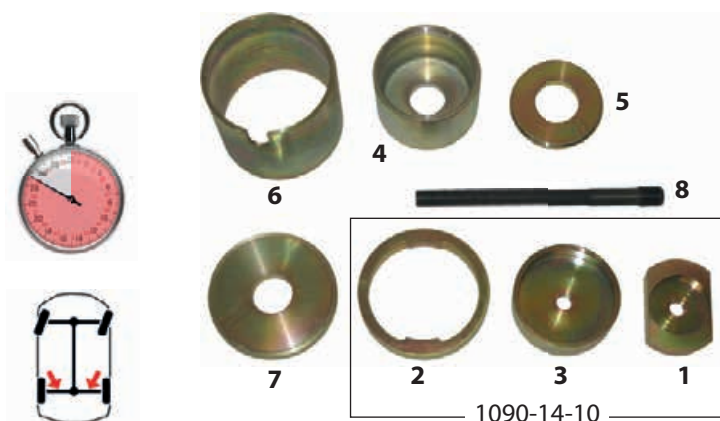

01-00014 Rear axle bushing set Hyundai Santa Fe 2006-2012

Set for replacement of all four bushings in the rear axle.
The job is made directly on the car with hydraulic power.
The rear axle is lowered with help of a gear box lift for easy access to the bushings.



Parts in set

1. 01-00014-001 - Press pipe
2. 01-00014-002 - Press plate
3. 01-00014-003 - Dismounting plate
4. 01-00014-004 - Press plate
5. 01-00014-005 - Mounting plate
6. 01-00014-006 - Dismounting plate
7. 01-00014-009 - Dismounting ring
8. 1090-20-R1 - Press pipe



1090-37-10 Supporting arm bushing set, rear bushings & sub frame bushings for Opel Vectra & Saab 9-5

Set for quick exchanging of rear bushings in rear supporting arm (4pc).
The job is done without dismounting of supporting arms.
For better access used cylinder 01-00030.

Parts in the set:

1. 1090-37-BL1 - Press socket, dismounting
2. 1090-37-BL2 - Press socket, mounting
3. 1090-37-BL3 - Holding ring, mounting
4. 1090-37-SU4 - Press pipe
5. RES4011 - Adaptor M22-M12
6. RES4015 - Carriage beam M12, 250mm



1091-13 Slewing bracket bushing set, front Ford Transit

Set for replacing of the rear bushing in the front slewing bracket.

Parts in the set:

1. 1091-13-01 - Press socket
2. 1091-13-02 - Press pipe
3. RES4010 - Adaptor M22-M14
4. RES4016 - Carriage beam M14, 250mm
5. RES4021 - Flange nut M14

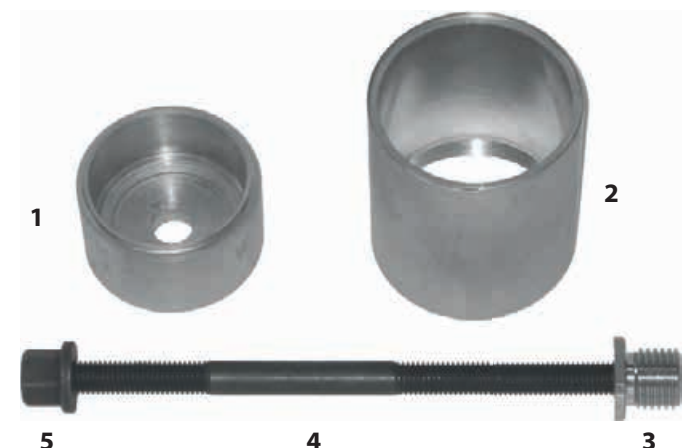

1062-01 Control arm bushing set, front VW, Audi, Seat, Skoda

Set for replacing of the rear bushing of the front control arm.
This set is for manual use.

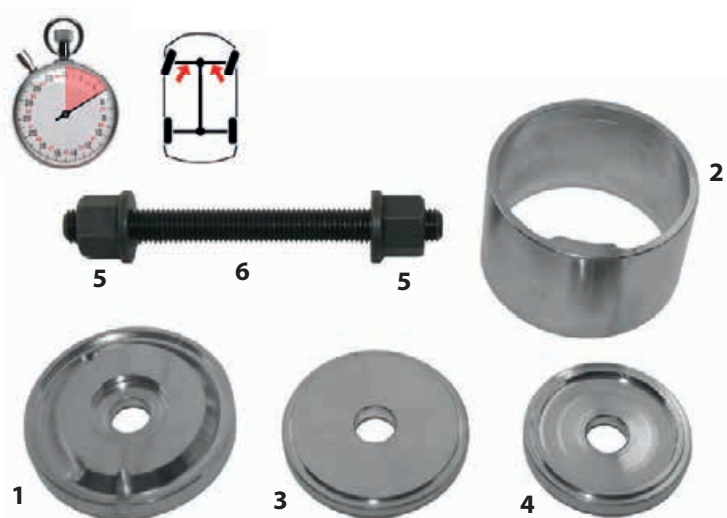

IN USE

Parts in the set:

1. 1062-01-01 - Dis-/mounting plate
2. 1062-01-02 - Press pipe
3. 1062-01-03 - Mounting plate
4. 1062-01-04 - Dismounting plate
5. 2 pcs RES4021 - Flange nut M14
6. RES4028 - Carriage beam M14, 150mm

01-00023 Bushing set for replacement of gear box supporting bushing in front sub frame VW, Seat, Skoda, Audi

VW: Caddy III (2004-2010), Eos (2006-), Golf V (2003-2009), VI (2008-), Scirocco (2005-), Jetta III (2005-2010),
Passat (2005-2010), Tiguan (2007-), Touran (2003-). SEAT: Altea (2004-), Leon (2005-), Toledo (2004-2009).
SKODA: Octavia (2004-2010). AUDI: A3 (2005), TT (2006-2010).

The set is used in the garage press due to limited access under the vehicle.
With this set the bushing in the engine supporting bushing in front sub
frame is replaced quick and easy.

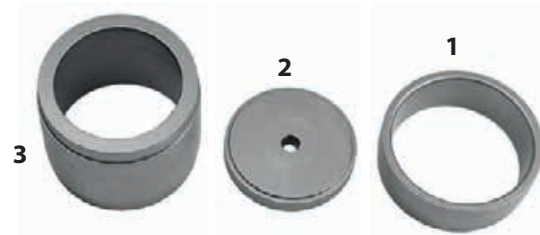

Parts in the set:

1. 01-00023-001 - Compression pipe
2. 01-00023-002 - Press plate
3. 01-00023-003 - Press pipe



01-00025 Bushing set rear in front support arm VW T5

Replacement is carried out directly on the vehicle with a minimum of dismantling.
A basic set that gives great time savings, labour time about 15 minutes.

Parts in the set:

1. 01-00025-001 - Press plate
2. 01-00025-002 - Sleeve
3. RES4010 - Adaptor M22-M14
4. RES4016 - Carriage beam M14, 250 mm
5. RES4021 - Flange nut M14



HSC2018 Hydraulic spring compressor

New version with three functions!

This unique spring compressor is designed to be a helpful and efficient tool when working with wheel suspensions. With unique adjustment possibilities and special jaws it covers almost every front and rear spring on passenger cars and light commercial vehicles. It also covers difficult models like Mercedes C and E-class and newer BMW models. Spring with Ø 150-240 mm.

It allows the mechanic to compress the spring and remove the shock absorber unit from the wheel spindle/knuckle directly on the car.

The same function can also be used to unload the lower control arm to its "driving" position when working with ball-joints or sway bars. With pressure on the spring, the lower plate rubber can be replaced in just minutes.

The upper frame can be mounted upside-down and be used as a lifting jack when working with other jobs on the suspension system. Very useful on both front and rear axle jobs.

A safe mobile unit that can be used anywhere in the shop.

The spring compressor comes with a safety strap for extra safe handling.

Used with hydraulic pump (700 bar) **1030** or **1036**.

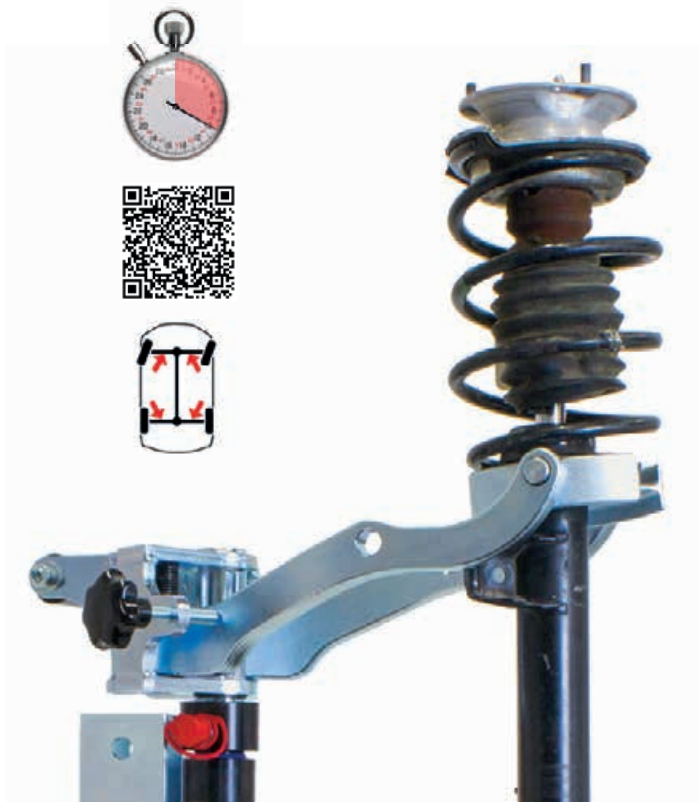

This function allows the operator to compress the spring and split the shock absorber unit from the wheel spindle/knuckle directly on the car. The same function can also be used to unload the lower control arm to its "driving" position when working with ball-joints or sway bars. With pressure on the spring instead of the lower plate, the lower plate rubber can be replaced in just minutes.

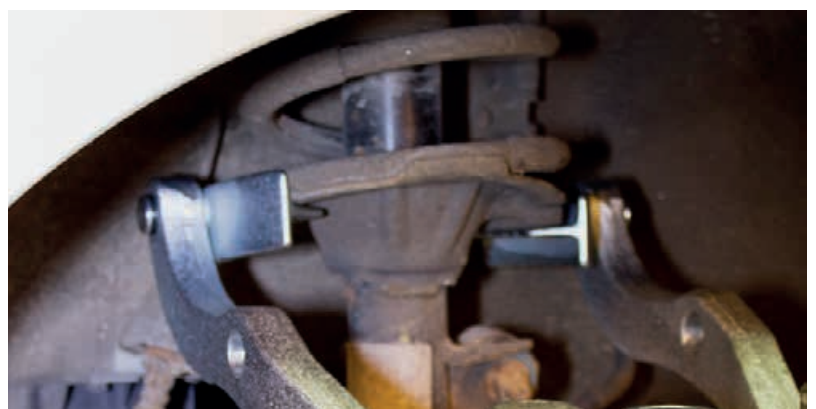

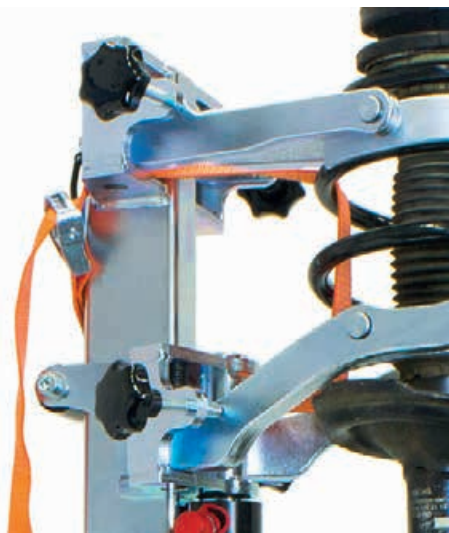

09-00016 Security strap
Included in HSC2018.



The upper frame can be mounted upside-down and be used as a lifting jack when working with other jobs on the suspension system.
Very useful on both front and rear axle jobs.

HSC2018-1126 Aluminum top
Included in HSC2018.



HSC2008-1146 Claw set for Ø 150–240 mm, 4 pcs
Included in HSC2018.



Special claws ordered separately, included in HSC2018-100.

HSC2008-1147 Claw set for Ø 70–160 mm, 4 pcs

Specially designed claw for multi-link front suspensions like MB 211 and others with a smaller diameter than standard MacPherson type. The claws are used for springs from Ø 70 – 160 mm. (4 pcs needed). **Included in HSC2018-100.**



HSC2008-1118-020 Claw set for Ø150-240 mm, 2 pcs

Specially designed for models like Chrysler Voyager 1996-2007, Citroën C3, Mercedes C class. (2 pcs needed). **Included in HSC2018-100.**



HSC2008-1119 Press ring

Used together with spring compressor for front spring jobs on Opel Insignia B 2017 -. The press ring makes the job safe and easy, it also gives a better press surface for the claws. This specific spring have only a few coils, it's therefor needed to press on the top bearing and the lowest part of the spring. **Not included in HSC2018 or HSC2018-100.**



Press tool sets

01-00001 Universal press tool set 1

A flexible, well thought-out and very useful set for bushings, ball-joints, certain bearings and more. Can also be delivered complete in a robust plastic case as 01-00006.

The set consists of 24 pc, with sizes ranging from 30,5 to 79,7 mm with small increments. Many of them have two usable sides to increase the number of combinations to 61! An adaptor and a press rod are included to be able to use press block 1090-60. This is very useful when working with bushings and ball-joints without holes. The larger sockets are made to fit bushings like the inner supporting arm bushings on BMW E38/E39 and Mercedes E/S class. The set is delivered like in the picture with a foam that holds the pieces in place, may also be wall mounted.

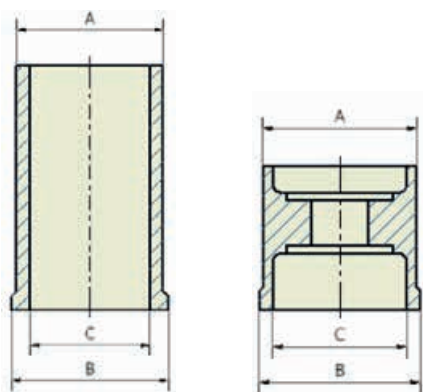

Universal set 1

001-00001-001 – Adaptor plate
01-00001-002 – Adjustable press axle 90mm, M24

Press pipes art:	∅ A mm	∅ B mm	∅ C mm
01-00001-101	40,7	42,5	35,2
01-00001-102	43,7	45,5	38,2
01-00001-103	46,7	48,5	41,2
01-00001-104	49,7	51,5	44,2
01-00001-105	52,7	54,5	47,2
01-00001-106	55,7	57,5	50,2
01-00001-107	58,7	60,5	53,2
01-00001-108	61,7	63,5	56,2
01-00001-109	65,7	67,5	60,2
01-00001-110	69,7	71,5	64,2

Press pipe art:	∅ A mm	∅ B mm	∅ C mm
01-00001-201	38,7	44,7	30,5
01-00001-202	41,7	44,7	34
01-00001-203	44,7	44,7	37,2
01-00001-204	47,7	55	40,2
01-00001-205	50,7	55	43,2
01-00001-206	53,7	55	46,2
01-00001-207	56,7	55	49,2
01-00001-208	59,7	70	52,2
01-00001-209	62,7	70	55,2
01-00001-210	65,7	70	58,2
01-00001-211	68,7	70	61,2
01-00001-212	71,7	70	64,2
01-00001-213	75,7	75,7	68,2
01-00001-214	79,7	79,7	72,2

01-00001-004 Adjustable press rod 95 mm M22

The press rod makes it possible to use the 8,5 ton hydraulic cylinder 03-00015 (M22) with the universal set 01-00001. This combination can be used with the following press frames: 1090-60, 1090-69 for smaller bushings or ball joints. The O-ring fitting locks the socket to the axle for easier handling.



01-00043-001 Adjustable press rod 170 mm M22, Klann adapter

The press rod makes it possible to use the 8,5 ton hydraulic cylinder 03-00015 (M22) with Klann press sockets. This combination can be used with the following press frames: 1090-60, 1090-69 for smaller bushings or ball joints.



01-00002 Universal press tool set 2

A well thought-out and very useful set that is used with 01-00001 for even greater flexibility. Can also be delivered complete in a robust plastic case as 01-00007. The set consists of 10 different press rings with sizes ranging from 52,2 to 81,2 mm in small increments, an open bottom part for press block 1090-60 and an adaptor plate that makes it possible to use Wallmek's other ball-joint tools in the open press block. It is very useful when working with bushings and ball-joints without holes. The set is delivered like in the picture with a foam that holds the pieces in place, can also be wall mounted.

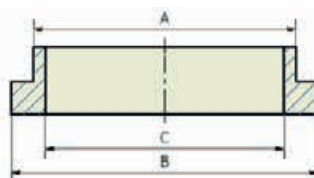

01-00002 Universal set 2

1090-60-05 Plate, open

Press ring	∅ A mm	∅ B mm	∅ C mm
01-00001-301	59	70	52,2
01-00001-302	62	70	55,2
01-00001-303	65	70	58,2
01-00001-304	68	70	61,2
01-00001-305	71	90	64,2
01-00001-306	74	90	67,2
01-00001-307	77	90	70,2
01-00001-308	80	90	73,2
01-00001-309	84	90	77,2
01-00001-310	88	90	81,2
01-00002-001	Foam		
1090-60-06	Adaptor		
1090-60-05	Plate with open side		

1011 Crank for brake disc

Crank for turning the brake disc when using scraper 1012 to clean the outer edge of it from rust.

1012 Scraper for brake disc

Scraper for cleaning the outer edge of brake discs and the position of the brake pads from rust. It's also possible to use crank 1011 for turning the brake disc when cleaning the brake disc.



01-00004 Lock ring tool

A new type of lock ring tool which makes dismounting and mounting of wheel bearing lock rings very easy. The tool is designed to fit both passenger cars, light commercial vehicles and trucks. The adjusting screw has a 1/4" ratchet grip which provides enough power to easily remove stuck and rusted lock rings.

The grip angle between the tips will also always be correct no matter the size or position of the lock ring. This makes the tool safer, more effective and easier to use than ordinary pliers.

It's delivered with a total of 6 specially designed tips that can easily be switched if needed.

Original since 2010. 6" for superior access.

- 01-00004-013 Circlip pin 2,5 mm, 4pcs
- 01-00004-014 Circlip pin 3 mm, 4pcs
- 01-00004-015 Circlip pin 3,5 mm, 4pcs



IN USE

03-00014-001 Hydraulic ball-joint puller

Press clamp for dismounting ball-joints on light commercial vehicles – MB Sprinter/ VW Crafter / Ford Transit.

The clamp is special designed to fit on most ball-joints on light commercial vehicles on the market. Moulded with special steel to withstand greater force.

Used with 8,5 ton cylinder 03-00015.



03-00030



Fuel handling for Petrol, Diesel and Ethanol (E85)

An efficient and very safe way to handle fuel. This drainer has no moving pump parts, this gives a very long life time compared to mechanical devices.



L1050-E Fuel tank drainer 115L

The fuel tank drainer is made of stainless steel with a volume of 115 litres approved for petrol, diesel and ethanol. It uses vacuum when draining the car, and pressure when emptying the fuel drainer. It is delivered with a set of adaptors and a special hose for long and complicated fuel filler necks (No: L1063). The suction hose uses a quick coupling for a fast, easy and tight connection. The fuel drainer is equipped with an overfill protector, safety vent and pressure regulator. Large wheels makes it mobile and easy to move. SAQ Approval TO 194/92 – 175 950. The fuel drainer has a very long lifetime since it does not have any movable parts that can get damaged by fuel or particles. Safe, fast (max 15 l/ min) and quiet operation. Fumes are disposed of through an exhaust hose. Adaptors No: 1, 2 and 3 are included in No: L1050-E.



Comes with the drainer:

- L1054-1 Fuel refill pipe
- L1054-2 Suction adaptor, coned
- L1063 Stainless steel hose with quick coupling for draining fuel through long, bent and complicated fuel tank filler necks with L1050 and L1050-E.
Diameter: 12mm. Length: 1,9m. Suction capacity: 7 litres/min.

Accessories

- 1. L1054-1 Fuel refill 15 litres/min
- 2. L1054-2 Suction adaptor, coned 7 litres/min
- 3. L1055-1 Adaptor male/female 8mm pipe
- 4. L1055-2 Adaptor male/female 9,5mm pipe
- 5. L1055-3 Adaptor male/female 10mm pipe
- 6. L1055-4 Adaptor male/female 12mm pipe
- 7. L1055-5 Adaptor female 14mm pipe



Included in L1050



Fuel suction hoses for long, bendt and complicated fuel filler necks:

- 8. L1063 Fuel suction hose 12mmØ, 1,9m Suction capacity: 7 litres/min
- 9. L1063-2 Fuel suction hose 8,5mmØ, 2,25m Suction capacity: 2,5 litres/min
- 10. L1063-4 Fuel suction hose 12mmØ, 3m 7 litres/min
- 11. 05-00007 Fuel suction hose with pipe for Volvo S80 (2007-) S80L, V70, XC60, XC70 (2008-).
The pipe makes it possible to also drain the passive half of the fuel tank.
- 12. 05-00008 Fuel suction hose with pipe for Volvo V60 – S60, (2011-).
The pipe makes it possible to also drain the passive half of the fuel tank.
- 13. L1063-2 Fuel suction hose 8,5mmØ, 3m Suction capacity: 2,5 litres/min
- 14. 05-00006 Adaptor for lid less filling (petrol/E10-85) filling necks.
Unlocks and gives acces for draining and filling of fuel.
- 15. 05-00010 Adaptor for lid less filling (diesel) filling necks.
Unlocks and gives access for draining and filling of fuel..



8, 9, 10, 13



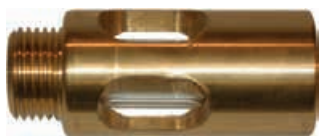

05-00001 Liquid indicator ½"

For mounting on the fuel tank drainer fuel hose. ½" pipe thread.

L2015 Water separator Petrol, Diesel and Ethanol (E85)

Cleans petrol and diesel effectively from water and particles.

For mounting on fuel tank drainer no: L1050-E.

Easy inspection through sight glass.

Drains from bottom valve. Volume 3,5 litres.

Picture shows separator mounted on fuel tank drainer.



L2620 Fuel fume evacuating hose

Hose unit for evacuating petrol and diesel fumes away from the vehicle during the work with fuel tanks. It can also be used when draining and filling the car. When working with an open fuel tank armature the mechanic is exposed to petrol fumes and the car's interior can smell of fuel afterwards. This is avoided by sucking out the fumes through the fuel refill pipe. The evacuating hose is powered by a compressed air ejector that produces vacuum in the tank. The hose are then connected to an approved exhaust fan. Standard length 2,5 metres. Contact us for custom lengths.



05-00009 Fuel drainer for trucks and busses

The fuel suction unit is intended, approved and EX classed for ethanol, diesel and petrol. It is equipped with 4 wheels but it can also be handled using a pallet lifter or a fork lifter. The fuel suction unit is made from stainless steel. Its capacity is 630 liters and it weighs 145 kg when empty. The fuel suction unit is powered by a pneumatic diaphragm pump that drains and fills with 20 lit/min. An overfill protection device automatically breaks the air supply to the pump if the fuel level in the fuel suction unit is too high.

The fuel suction unit is equipped with a bleed hose fitted with a flame guard, which is connected to the vehicle exhaust extraction system when draining vehicles to achieve odorless fuel handling.

The unit is supplied with three suction and filler adaptors.

1. L1054-1 Fuel refill 15 litres/min
2. 05-00009-002 Fuel hose ½", 3 m
3. 05-00009-003 Adaptor Tema 1800 – Parker NS

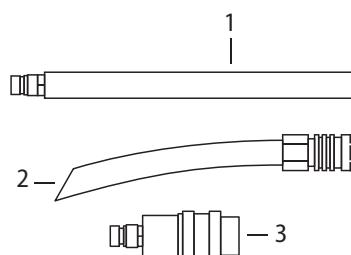

630L



Storage



04-00022 Tool trolley with 9 drawers

Double tool trolley with totally 9 drawers developed for Wallmek tool sets and foams. The trolley is equipped with a large top drawer for cylinders and accessories. All drawers are locked individually and with a central lock system for extra safety during transport, storage and normal use. All drawers open fully with heavy duty ball bearing slides and can be loaded with 90 kg.

Tools not included.

Measures internal for each drawer:

- 4 pc H100×W585×D418 mm
- 3 pc H150×W585×D418 mm
- 1 pc H250×W585×D418 mm
- 1 pc H100×W1243×D418 mm (top drawer)

An extra high drawer can be ordered individually. H250×W585×D418mm.

To be used instead of the two lower drawers on the right hand side.

Outside dimensions H1060×W1350×D460 mm.

See foames on pages 47–49.

The large axle wheels in combination with four swiveled wheels make the trolley easy to handle also fully loaded with tools.

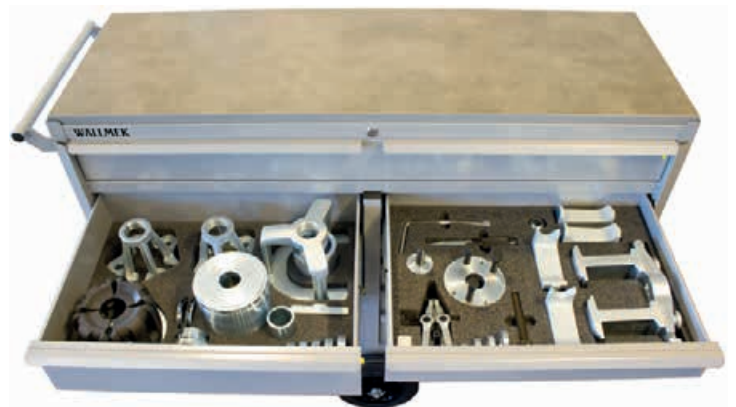

Large work surface.



Ball bearing slides for 90 kg load in each box!



Central lock for safe storage!

Foam for tool trolley 04-00022. Tools not included.

04-00022-001 Foam, dimension 580×415×145

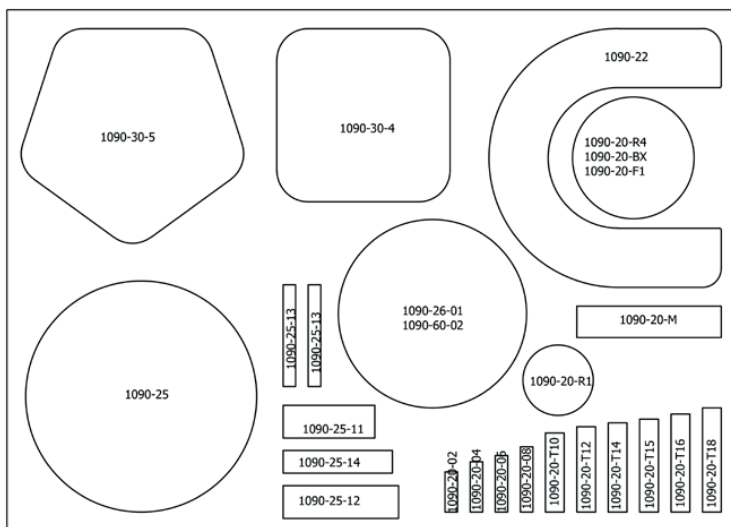

04-00022-002 Foam, dimension 580×415×97

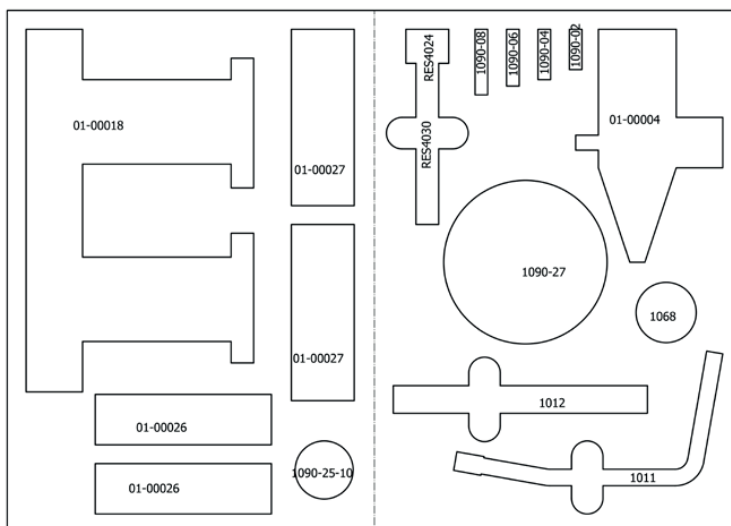

04-00022-003 Foam, dimension 580×415×95

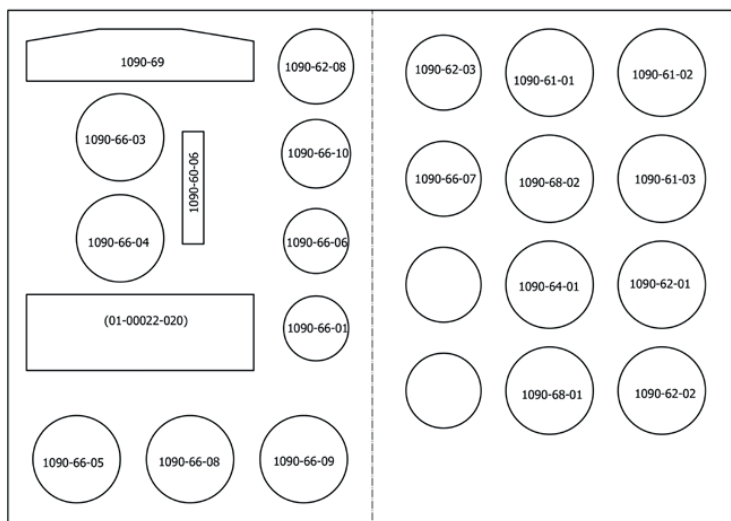

04-00022-005 Foam, dimension 580×415×197

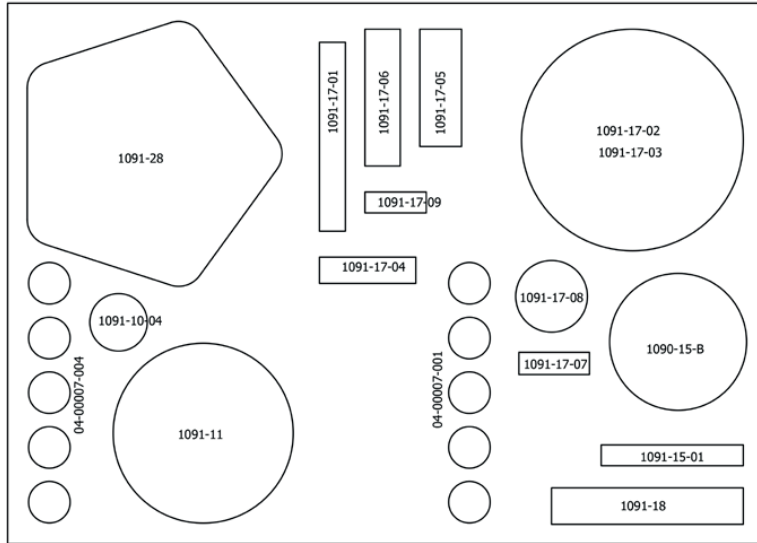

04-00022-006 Foam, dimension 580×415×197

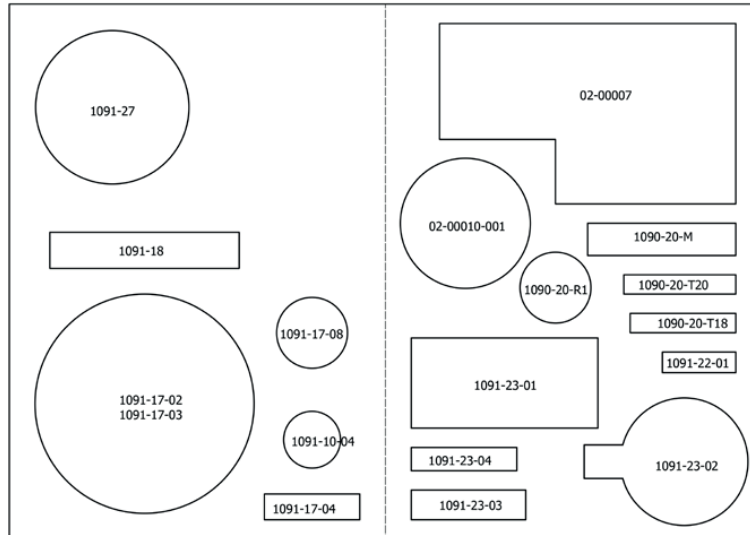

04-00022-007 Foam, dimension 580×415×128

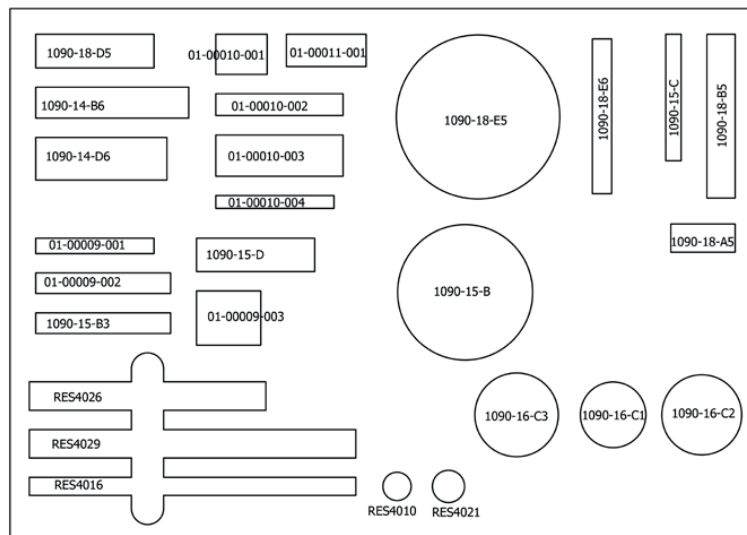

04-00022-014 Foam, dimension 580x415x90

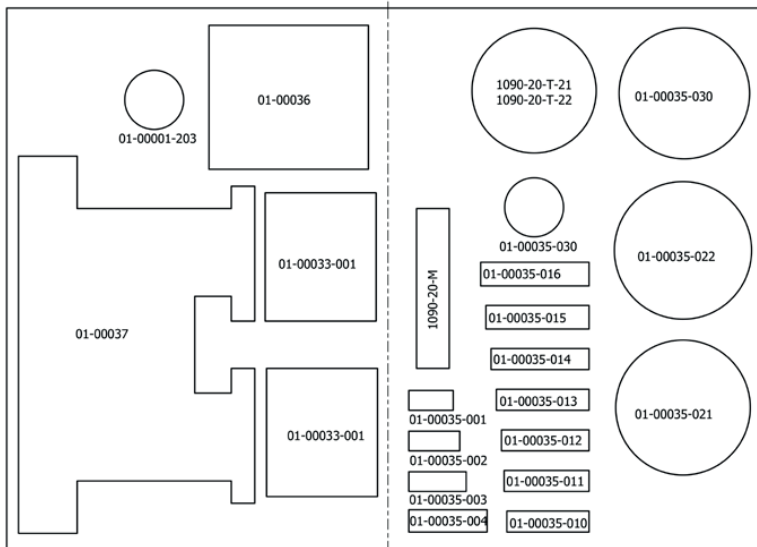

04-00022-015 Foam, dimension 580x415x90

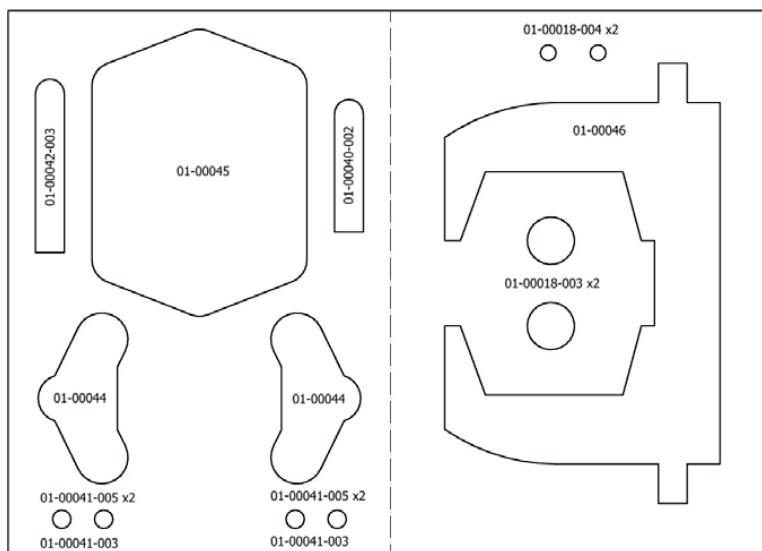

04-00023 Stackable plastic tool box

A strong plastic stackable tool box for efficient storage of tools and cylinders. This solution fits also perfect when transporting the equipment between different shops.

Foams to fit in the boxes are delivered with the following tools and sets; 01-00035, 01-00022, 01-00018, 01-00026, 01-00027, 01-00033 and 01-00037.

Outer dia; 464x335x212h mm.
Inner dia; 400x300x150h mm.

The foams can also be ordered separately, see information below.

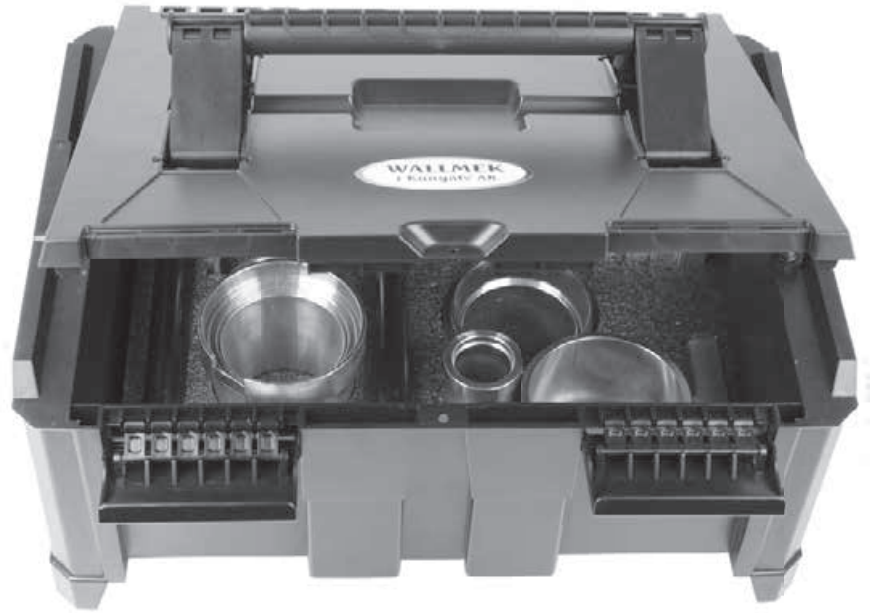

04-00023-001, 290×195 mm

Foam for 01-00035

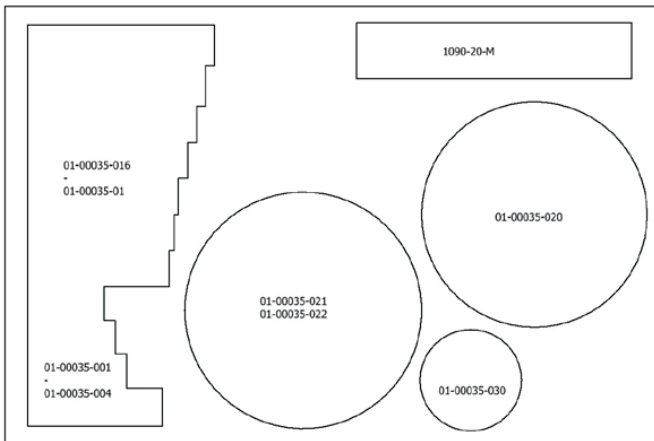

04-00023-002, 290×390 mm

Foam for 01-00018/33/-100 – 110 - 120

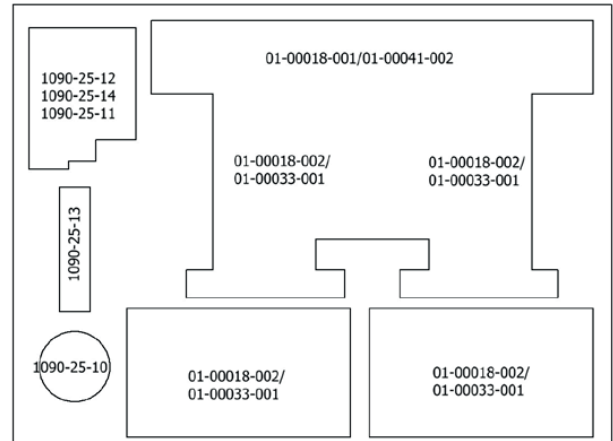

04-00023-003, 290×390 mm

Foam for 01-00026/27/37

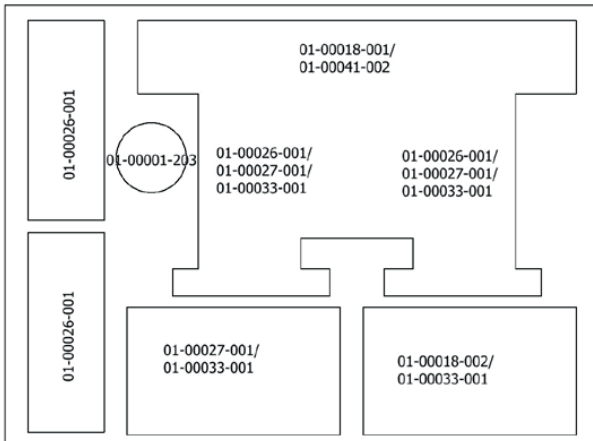

04-00023-004, 290×195 mm

Foam for 01-00022

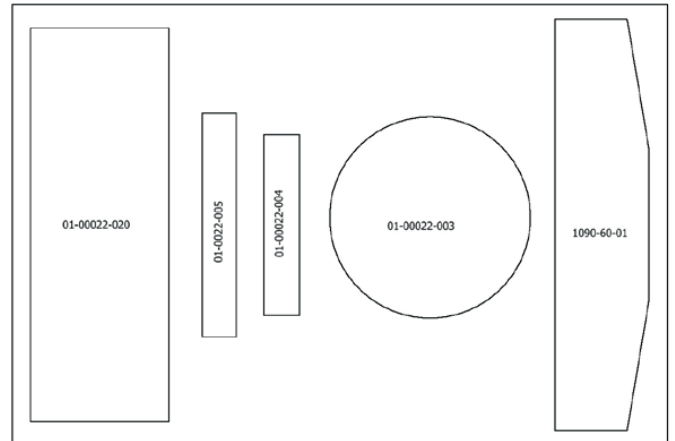

This tool and storage system is made for all automotive and truck garages that wants to take the next step in efficiency and profit. The technician can put all his time in to fixing the job instead of spending time trying to find the right tools.



1090-50 Tool cart

A sturdy construction with a large working surface. The large wheels makes it easy to transport also fully loaded.

Three different shelf/hook sets is available:
1090-51, 1090-52 and 1090-53.

Tools not included.



1090-51 Tool holder for 01-00035.







**1090-52 Tool holder for 1090-30,
01-00033 eller 1090-15.**



1090-53 Tool holder for for trucks.

INVEST IN TIME



-  **Passenger cars**
-  **Light Commercial**
-  **Trucks**
-  **Fuel handling**
-  **Car dismantling**

Address

Bultgatan 18
442 40 Kungälv
Sweden

Contact

Phone: +46 (0)303 - 585 80
Fax: +46 (0)303 - 942 46
E-mail: info@wallmek.se

Distributor



www.wallmek.se